

# COMUNE DI FAENZA

VARIANTE

## VARIANTE AL PIANO DI RIQUALIFICAZIONE URBANA AREA EX DISTILLERIE NERI via NAVIGLIO, via S.SILVESTRO, S.P. S.SILVESTRO, via MAESTRI DEL LAVORO \_ FAENZA CON MODIFICA DEL PERIMETRO DI INTERVENTO

Ubicazione e dati catastali

via della Costituzione, via Cora, via Fanfani - Faenza (RA) \_ Fg. 116 Mapp. 1919-1967-1923-1924-1905-1874-1870-1871-1873-1853-1872

Proprietà/Committente

Commercianti Indipendenti Associati Soc. Coop. - via Dei Mercanti, 3 - 47100 Forlì - p. IVA 00138950407

## SCHEDE TECNICHE TIPOLOGICHE

maggio 2019

# E\_2019



### COOPROGETTO

via Severoli, 18 - 48018 Faenza (RA)

tel. 0546-29237 - fax. 0546-29261

Progettista

**arch. Alessandro Bucci**

Collaboratori

arch. Stefano Martinelli

arch. Francesca Mura

arch. Simona Tartaglia

geom. Angela Esposito



Progettazione ambientale e acustica

**Dott. Geol. Daniela Tonini**

Via A. Bonci n.9 \_ 47921 Rimini

Tel +39 0541 411204 Fax +39 0541 411204

www.toniniambiente.it \_ info@toniniambiente.it

**Studio Geologico Ortelli  
di Ortelli Matteo**

Via Ragazzini 3/1 - 48018 FAENZA

Tel./Fax 0546-33141

Email: maortelli@racine.ra.it

Pratiche precedenti

AUT. 927-2007 / AUT. 231-2009 / AUT. 27544-2011 / AUT. 7589-2013

revisione	data

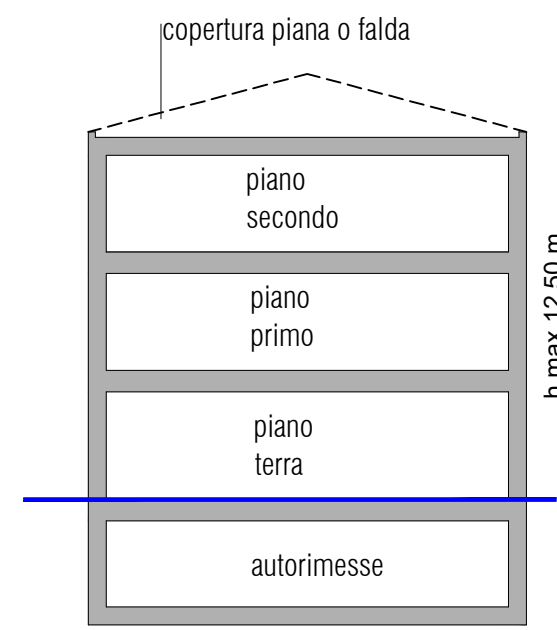
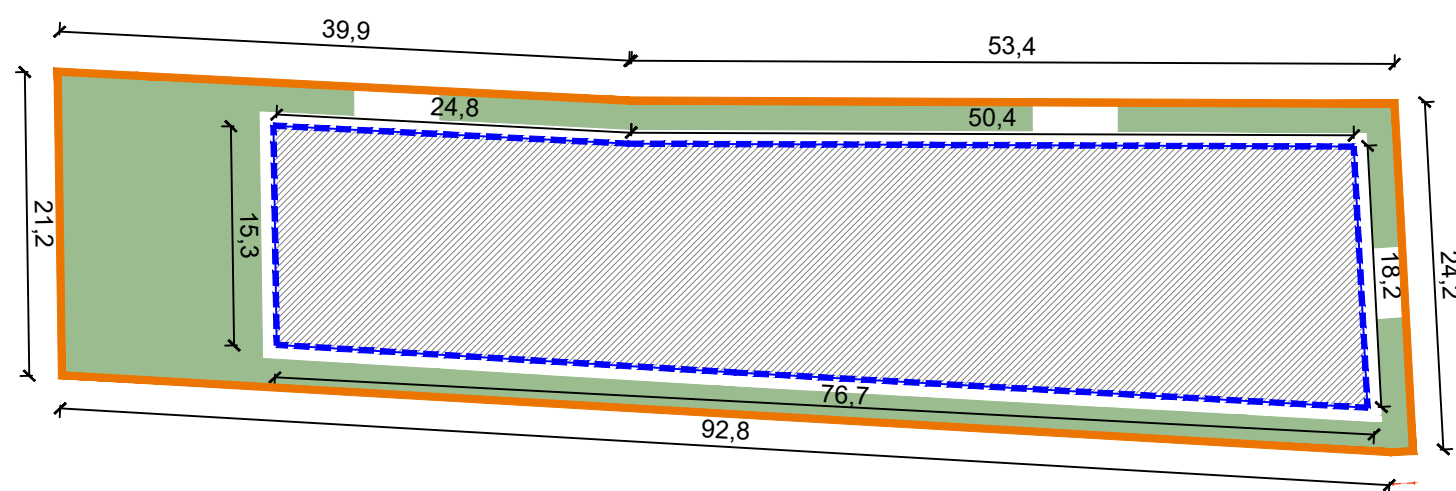
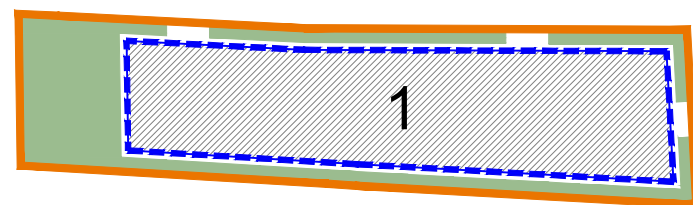

SEZIONE TIPO

LOTTO mq	SCO mq =max ingombro	H max ml	livelli n.	SUL max mq	Volume mc	SP mq	IP
						100%	
2 085	1 239	12.50	3	3 718	12 834	625	>30%

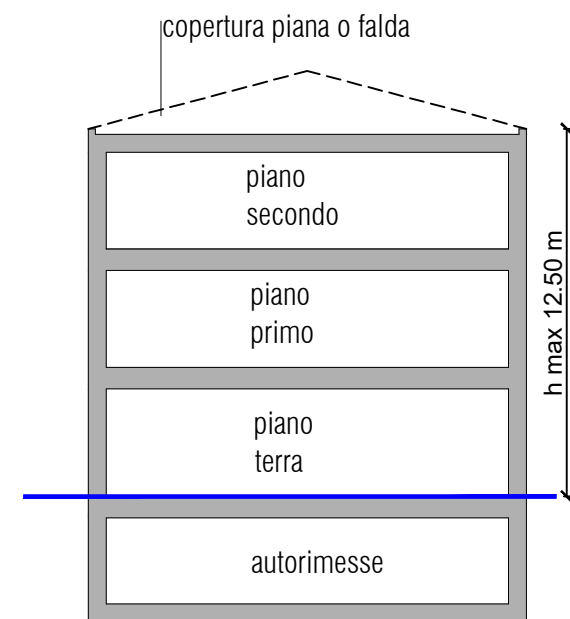
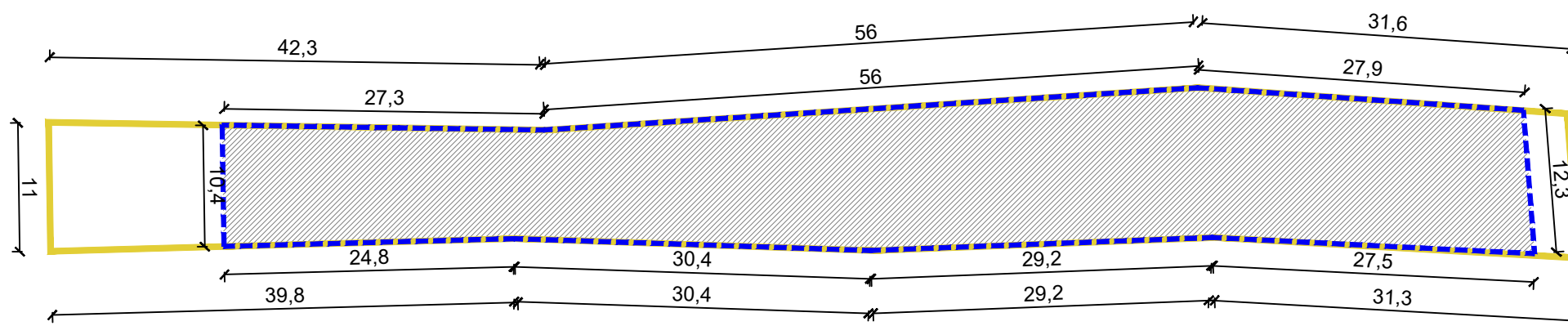
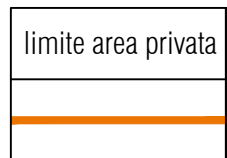
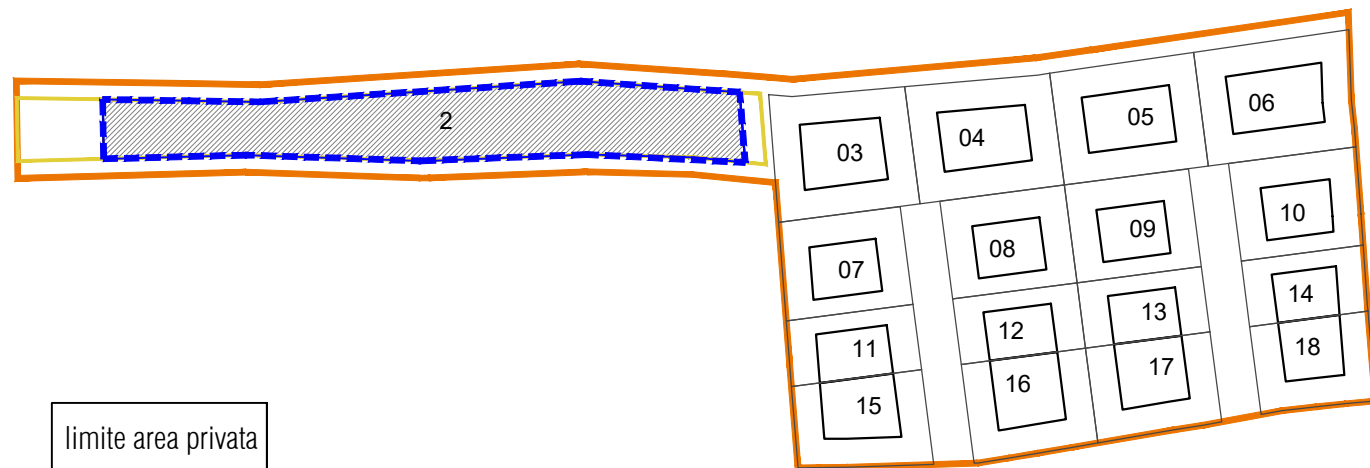

SEZIONE TIPO

LOTTO mq	SCO mq =max ingombro	H max ml	livelli n.	SUL max mq	Volume mc
1 464	1 261	12.50	3	3 783	13 051

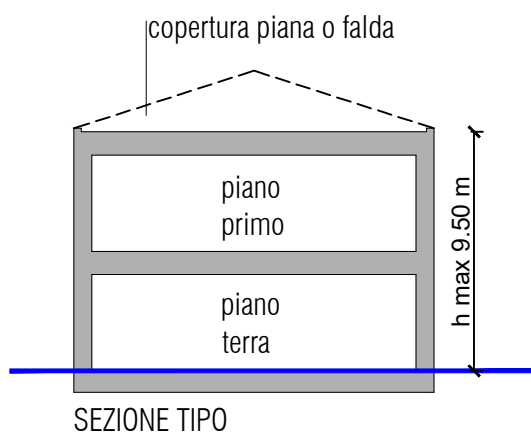
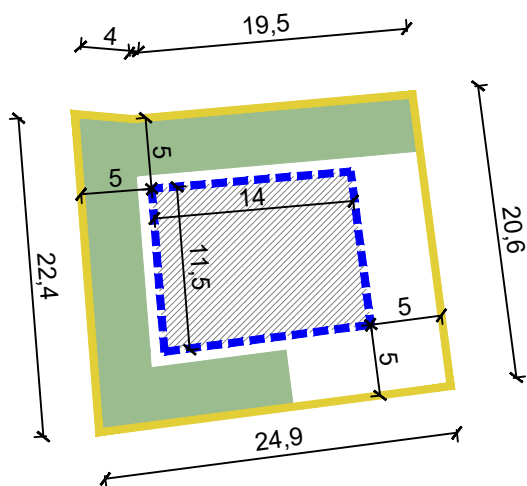
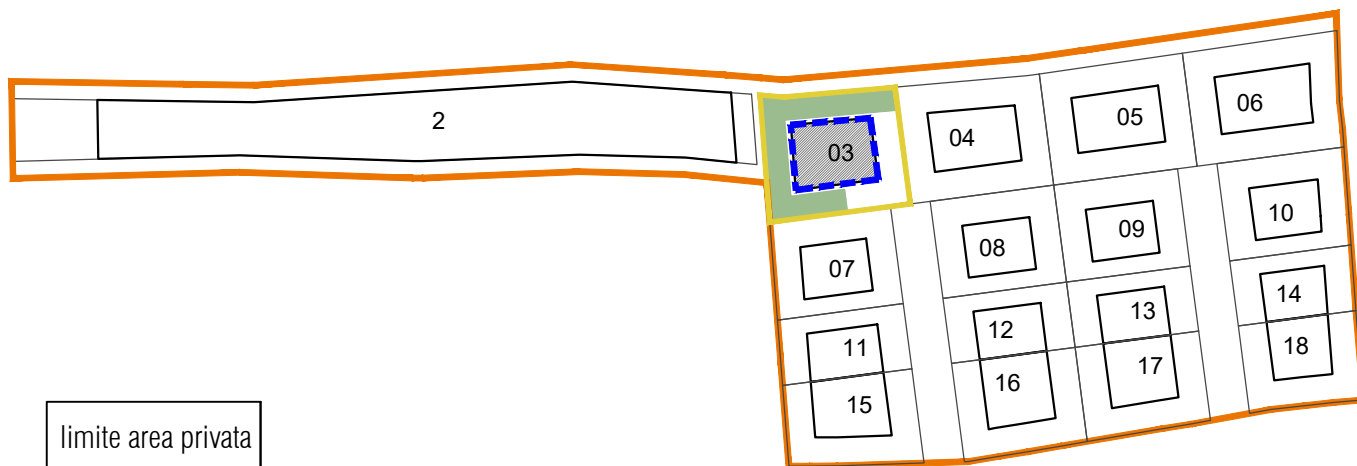

LOTTO mq	SCO mq =max ingombro	H max ml	livelli n.	SUL max mq	Volume mc
515	159	9.50	2	318	1 065

SP mq	IP
100%	
206	> 30%

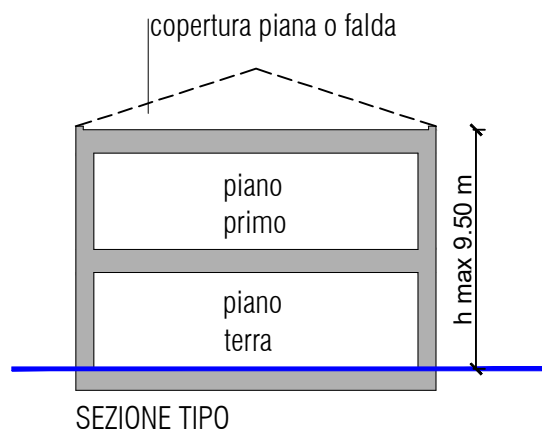
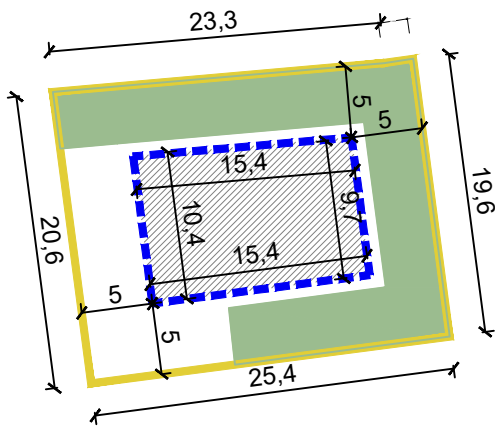
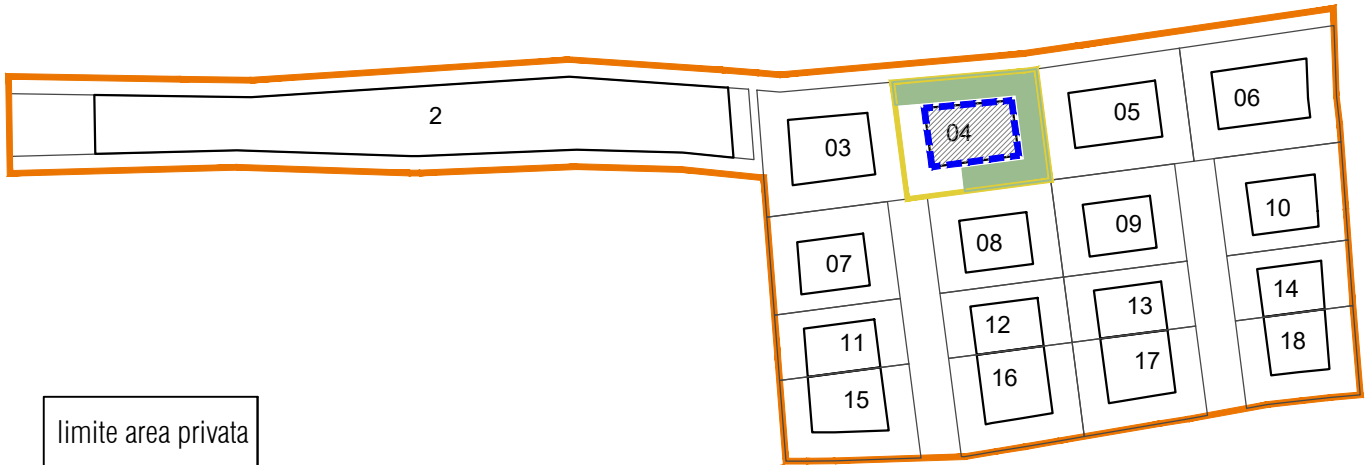

LOTTO mq	SCO mq =max ingombro	H max ml	livelli n.	SUL max mq	Volume mc
509	154	9.50	2	308	1 032

SP mq	IP
100%	
209	> 30%

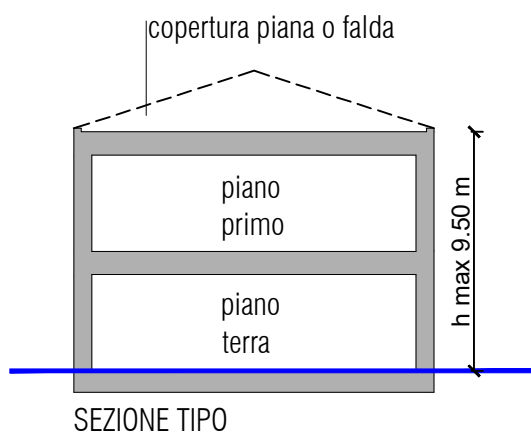
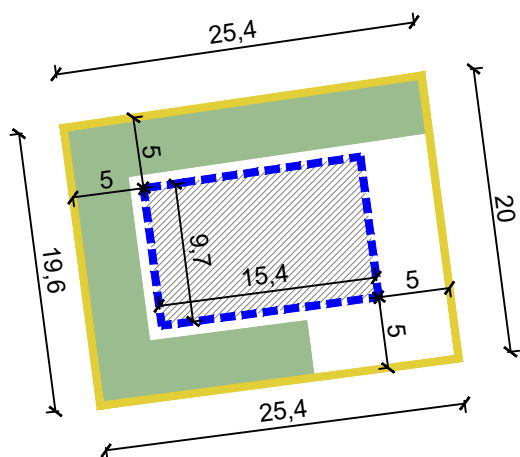
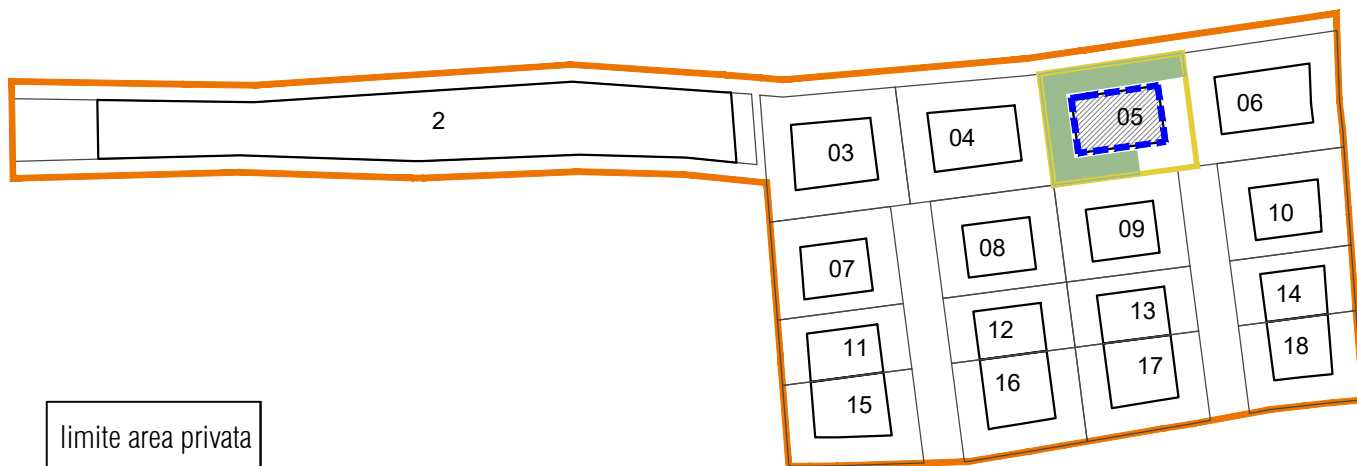

LOTTO mq	SCO mq =max ingombro	H max ml	livelli n.	SUL max mq	Volume mc
502	150	9.50	2	300	1 005

SP mq	IP
100%	
209	> 30%

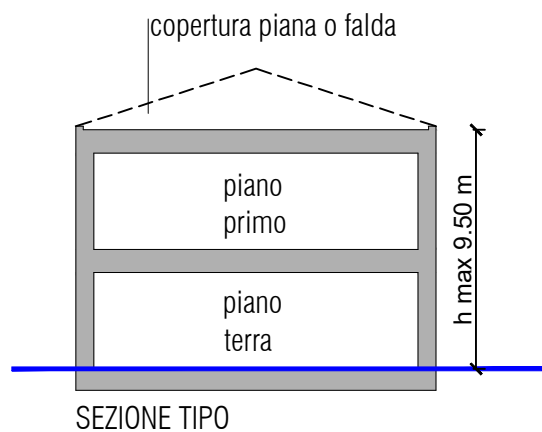
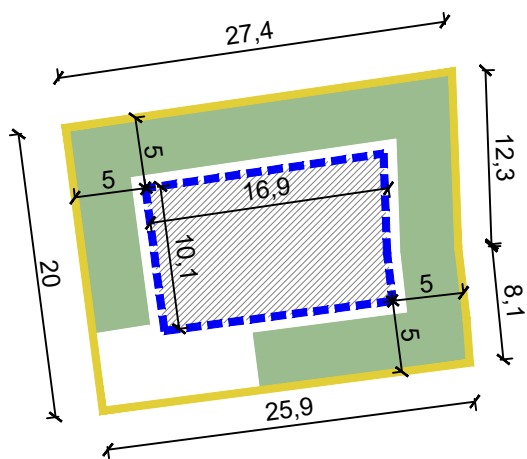
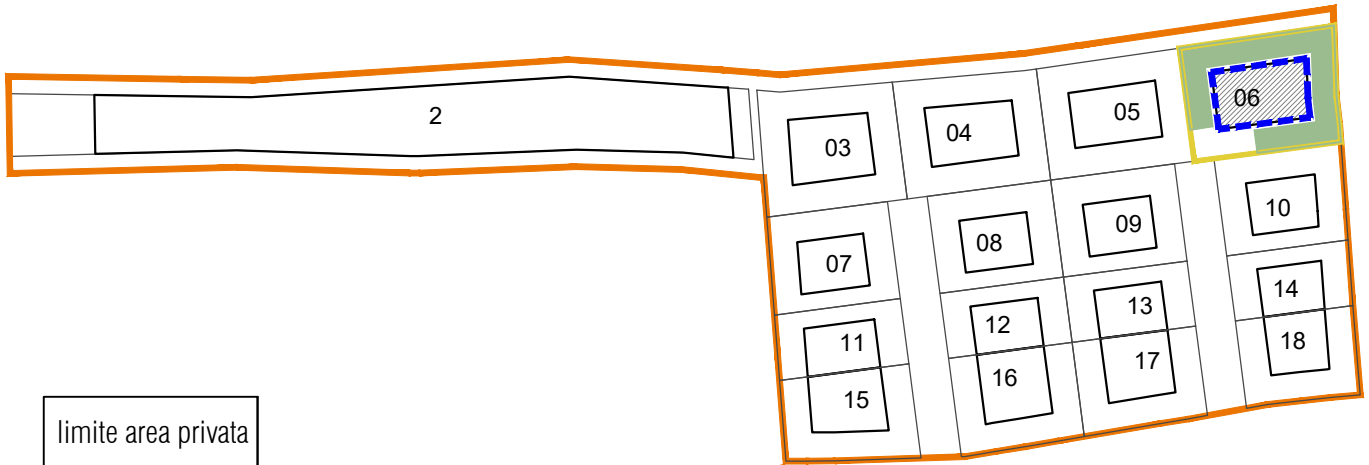

LOTTO mq	SCO mq =max ingombro	H max ml	livelli n.	SUL max mq	Volume mc
535	167	9.50	2	334	1 119

SP mq	IP
100%	
260	> 30%

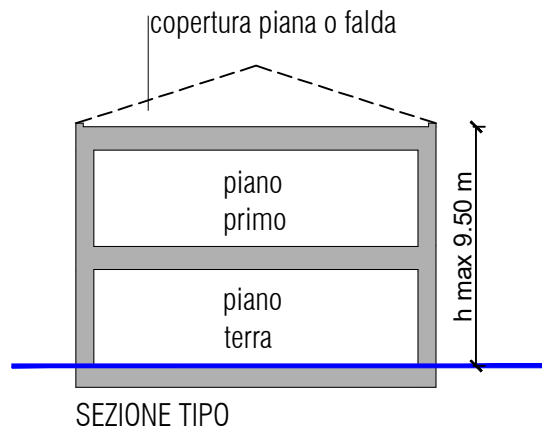
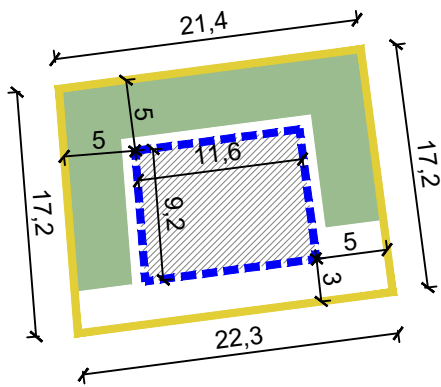
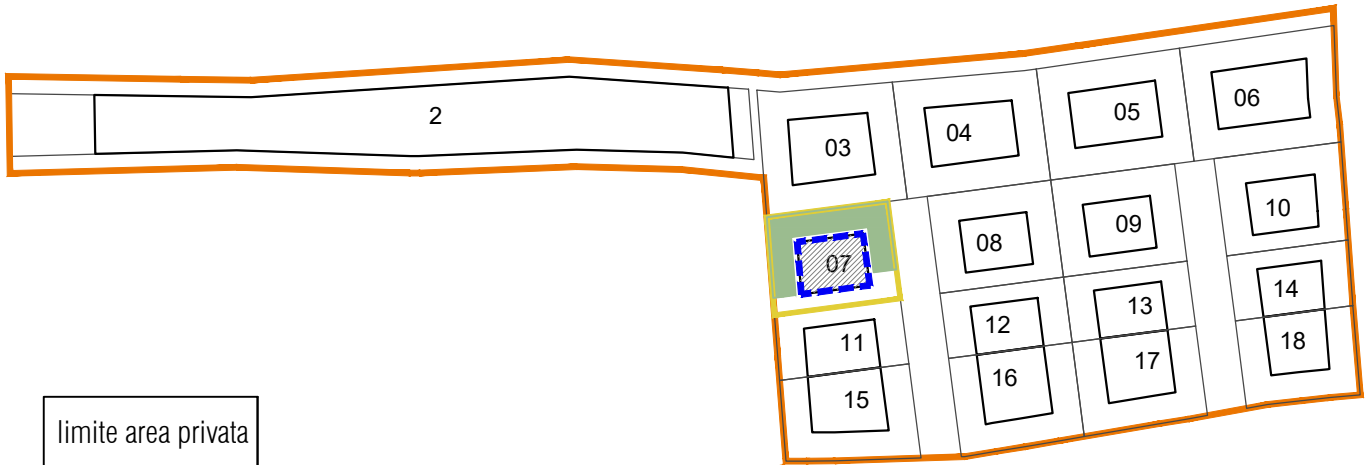

LOTTO mq	SCO mq =max ingombro	H max ml	livelli n.	SUL max mq	Volume mc
374	108	9.50	2	216	724

SP mq	IP
100%	
158	> 30%



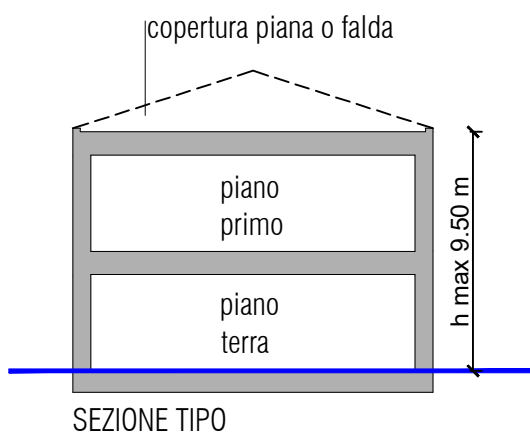
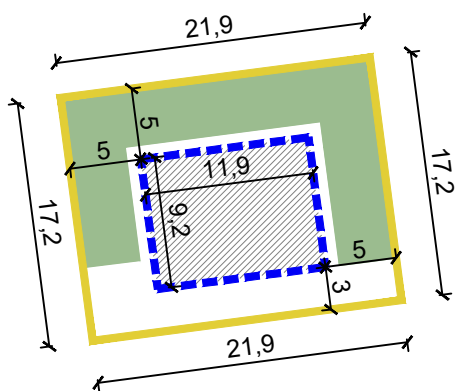
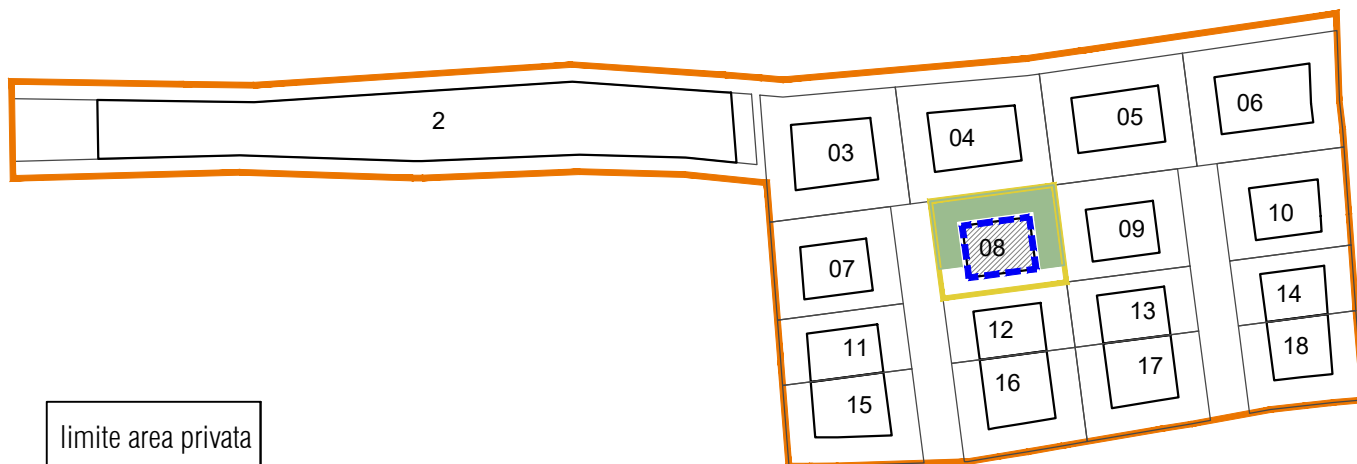

LOTTO mq	SCO mq =max ingombro	H max ml	livelli n.	SUL max mq	Volume mc
375	108	9.50	2	216	724

SP mq	IP
100%	
160	> 30%

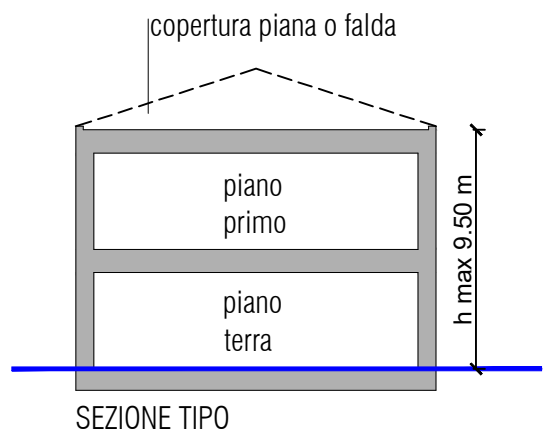
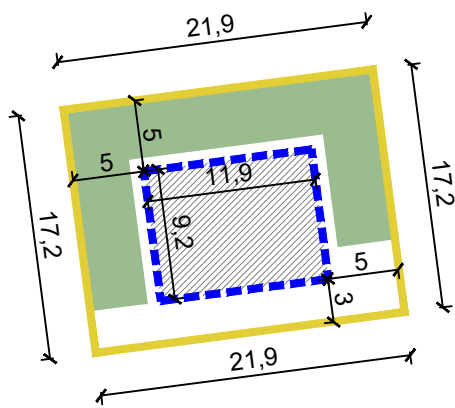
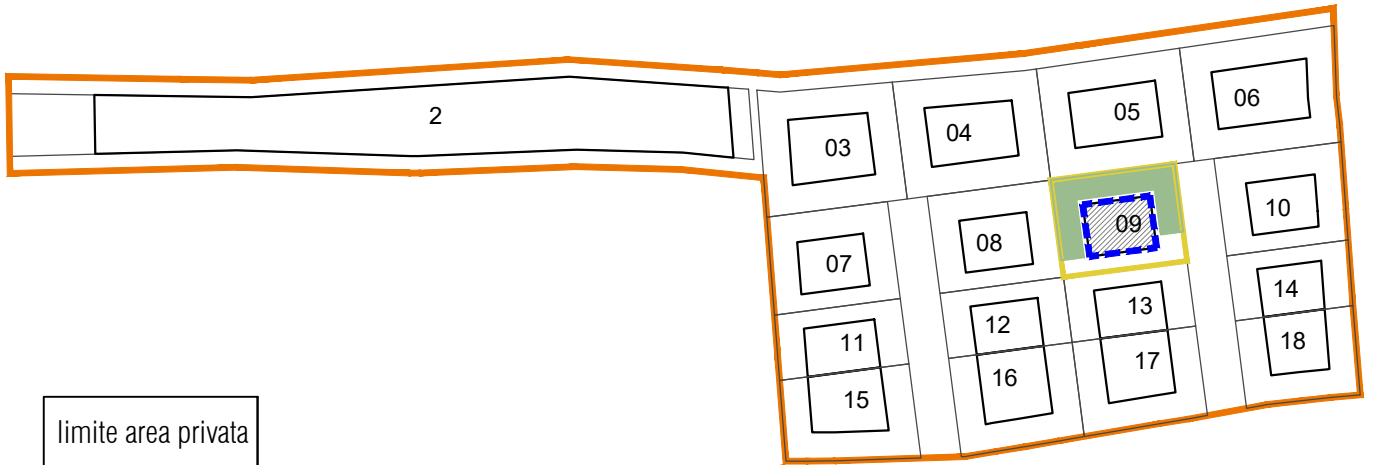

LOTTO mq	SCO mq =max ingombro	H max ml	livelli n.	SUL max mq	Volume mc
375	108	9.50	2	216	724

SP mq	IP
100%	
160	> 30%

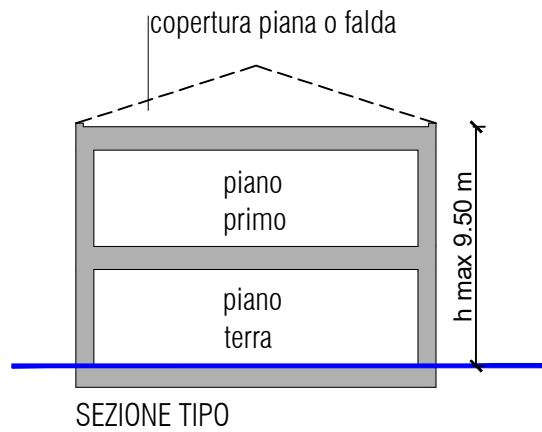
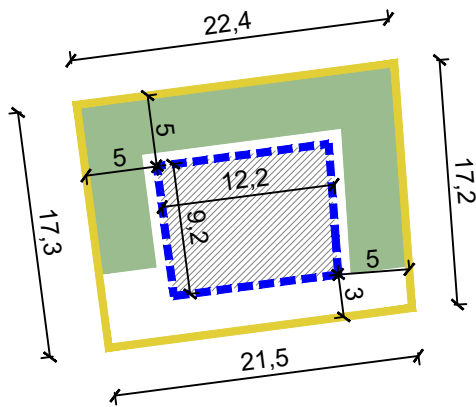
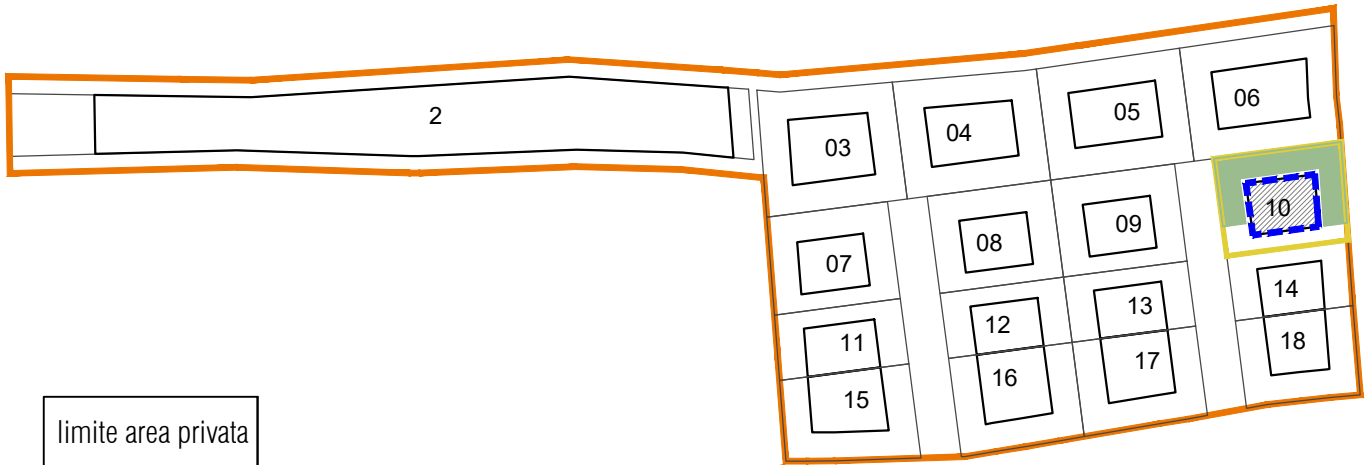

LOTTO mq	SCO mq =max ingombro	H max ml	livelli n.	SUL max mq	Volume mc
377	109	9.50	2	218	730

SP mq	IP
100%	
162	>30%

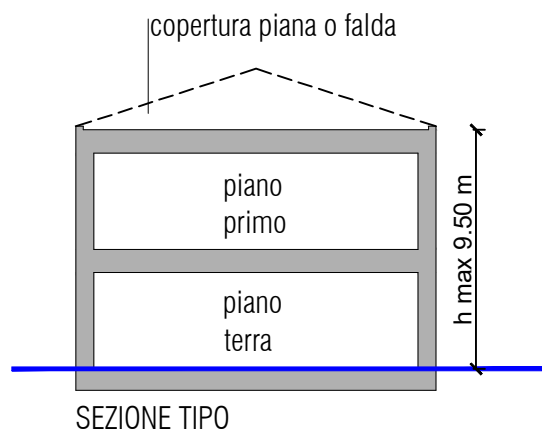
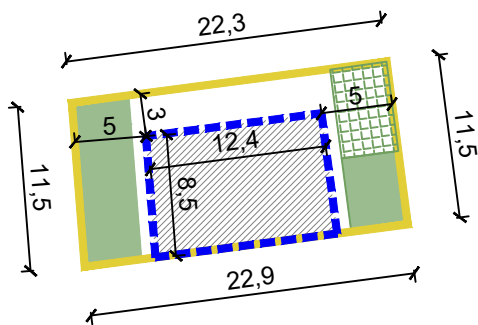
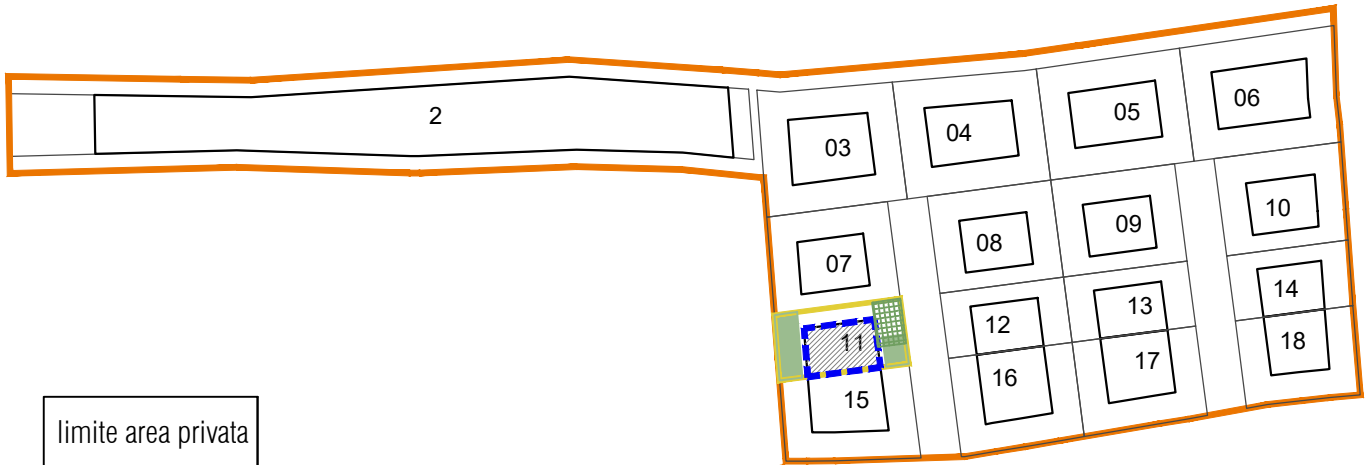

LOTTO mq	SCO mq =max ingombro	H max ml	livelli n.	SUL max mq	Volume mc
259	107	9.50	2	214	717

SP mq	SP mq	IP
100%	betonelle drenanti 20%	
67	101x0,20=20	> 30%

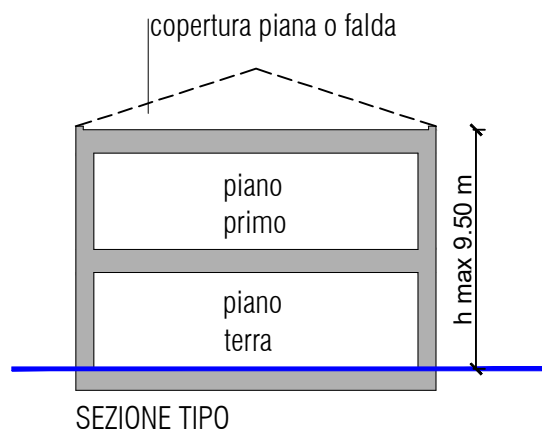
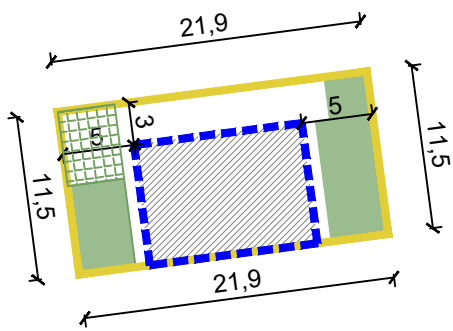
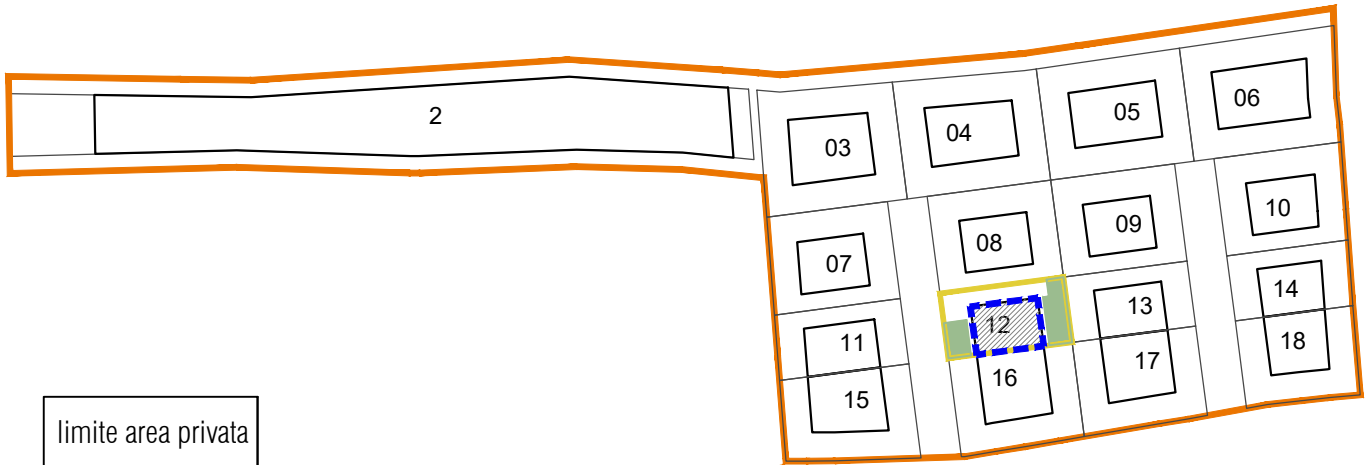

LOTTO mq	SCO mq =max ingombro	H max ml	livelli n.	SUL max mq	Volume mc
251	100	9.50	2	200	670

SP mq	SP mq	IP
100%	20%	
68	83x0,20=17	> 30%

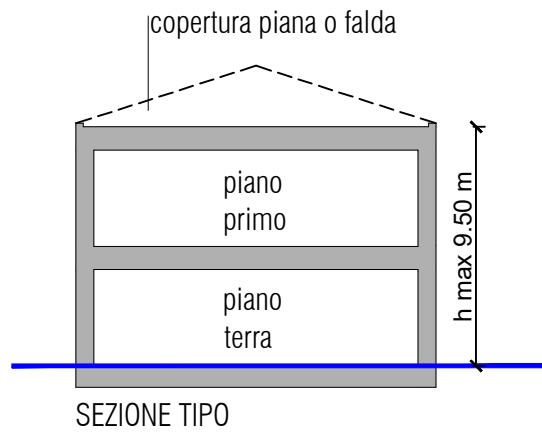
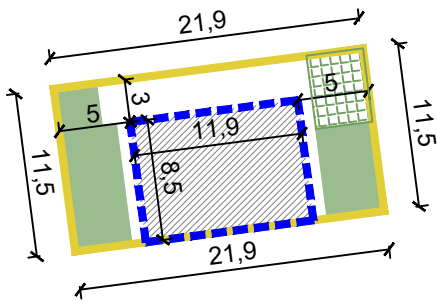
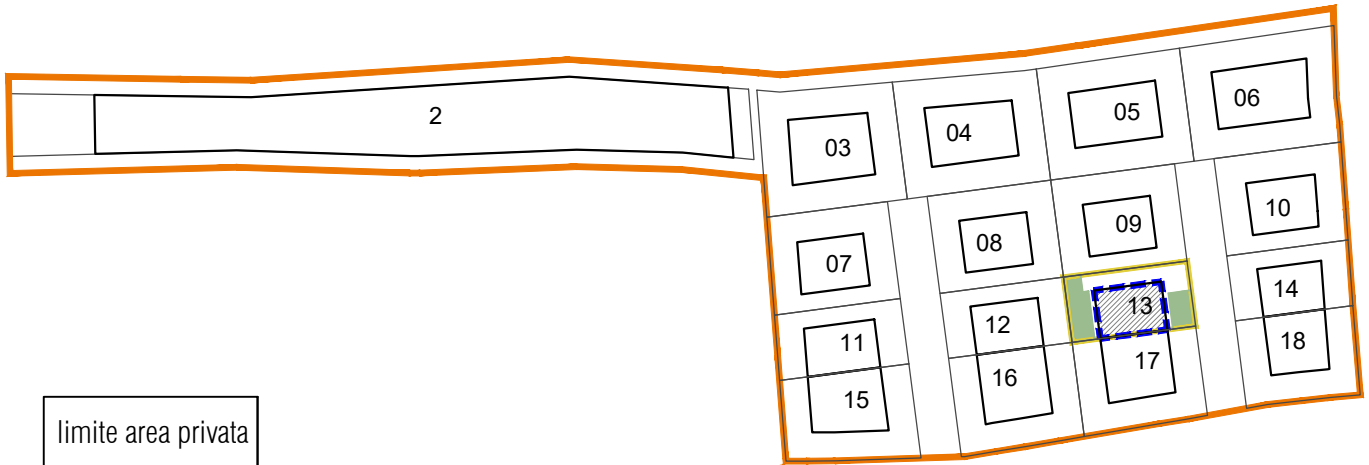

LOTTO mq	SCO mq =max ingombro	H max ml	livelli n.	SUL max mq	Volume mc
251	100	9.50	2	200	670

SP mq	SP mq	IP
100%	20%	
68	83x0,20=17	> 30%

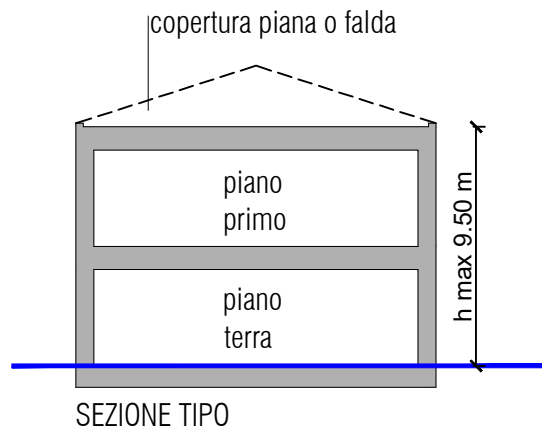
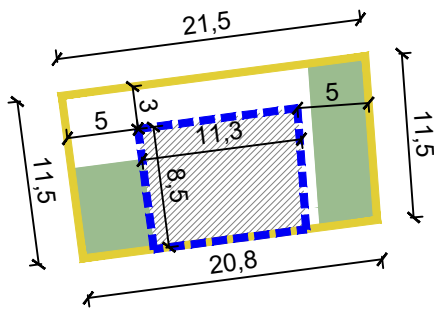
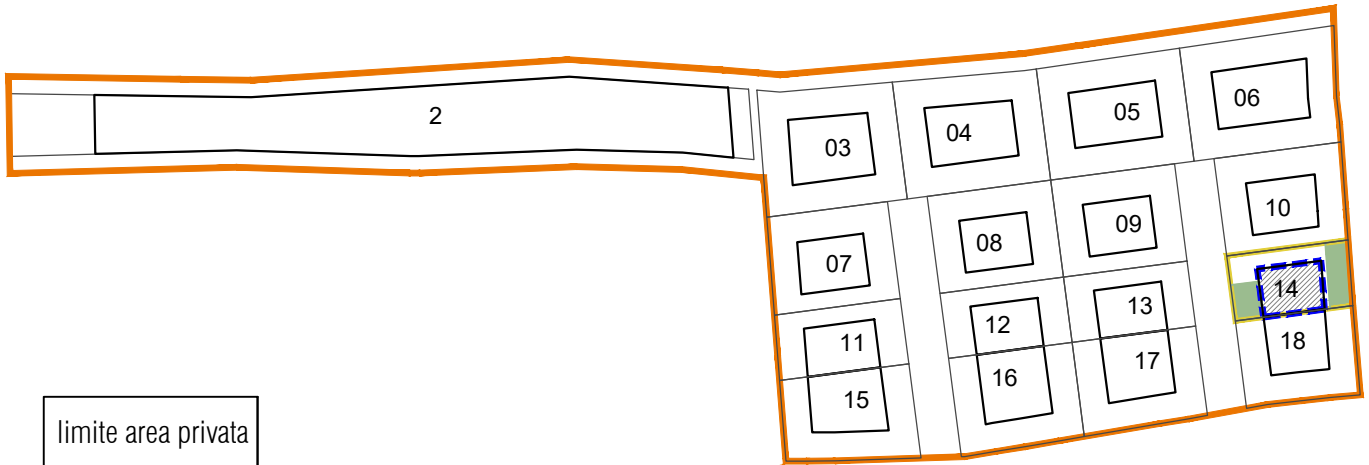

LOTTO mq	SCO mq =max ingombro	H max ml	livelli n.	SUL max mq	Volume mc
242	93	9.50	2	186	623

SP mq	IP
100%	
77	> 30%

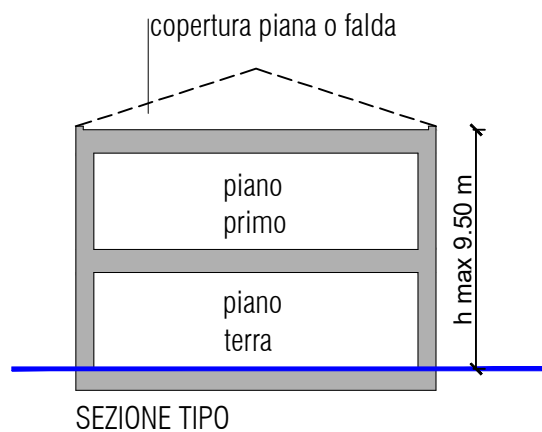
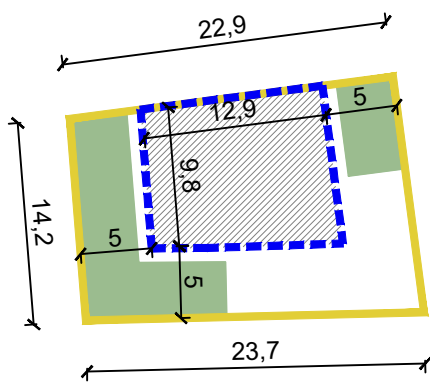
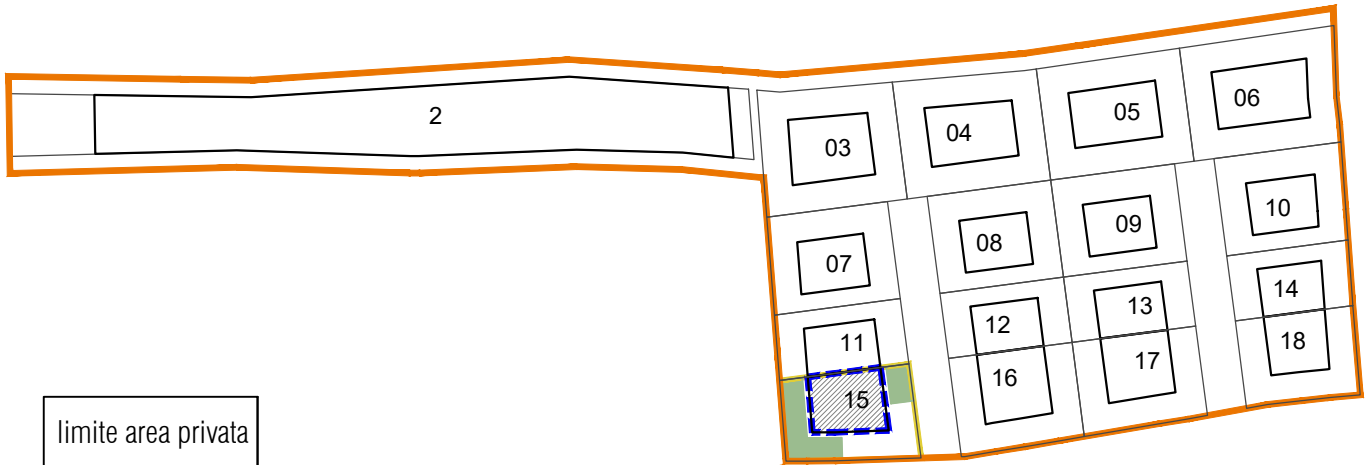

LOTTO mq	SCO mq =max ingombro	H max ml	livelli n.	SUL max mq	Volume mc
359	137	9.50	2	274	918

SP mq	IP
100%	
108	> 30%



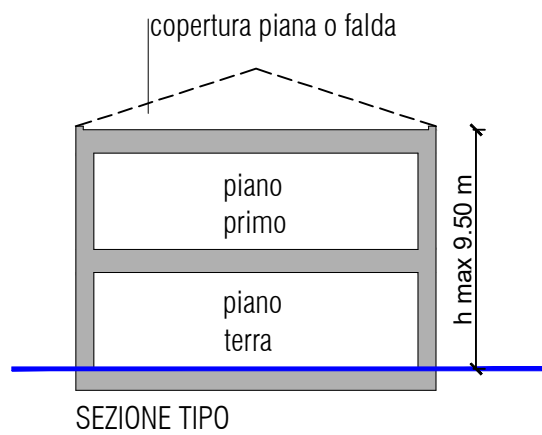
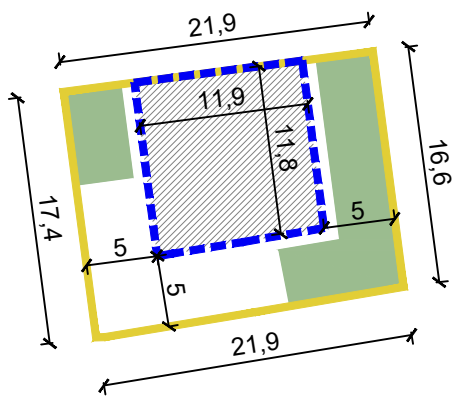
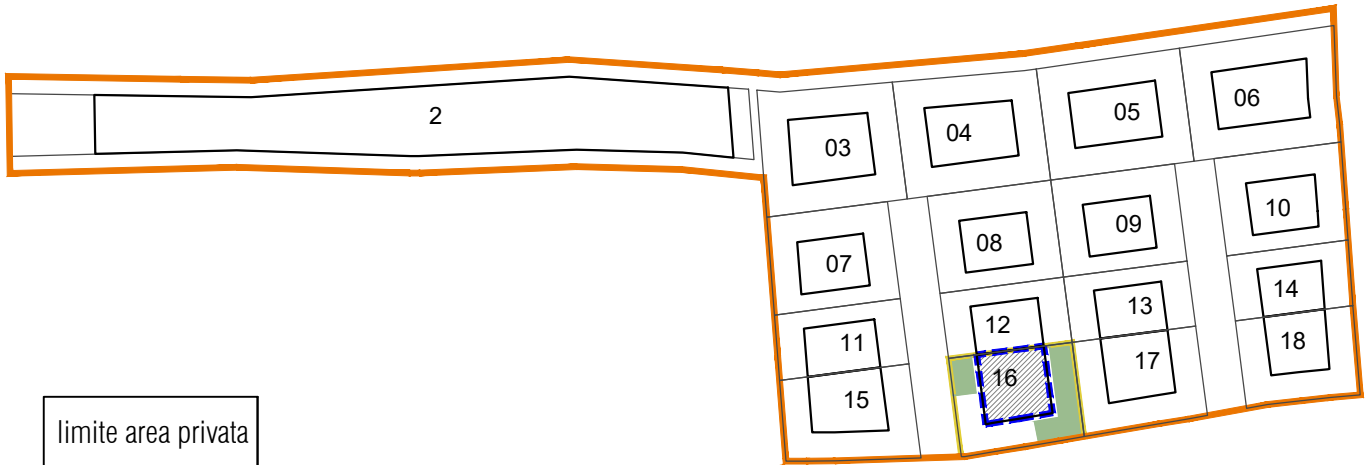

LOTTO mq	SCO mq =max ingombro	H max ml	livelli n.	SUL max mq	Volume mc
372	143	9.50	2	286	958

SP mq	IP
100%	
111	> 30%

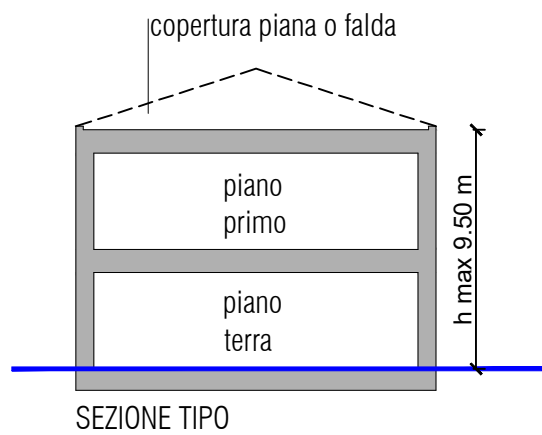
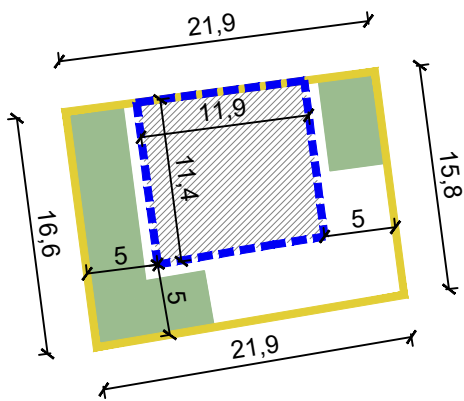
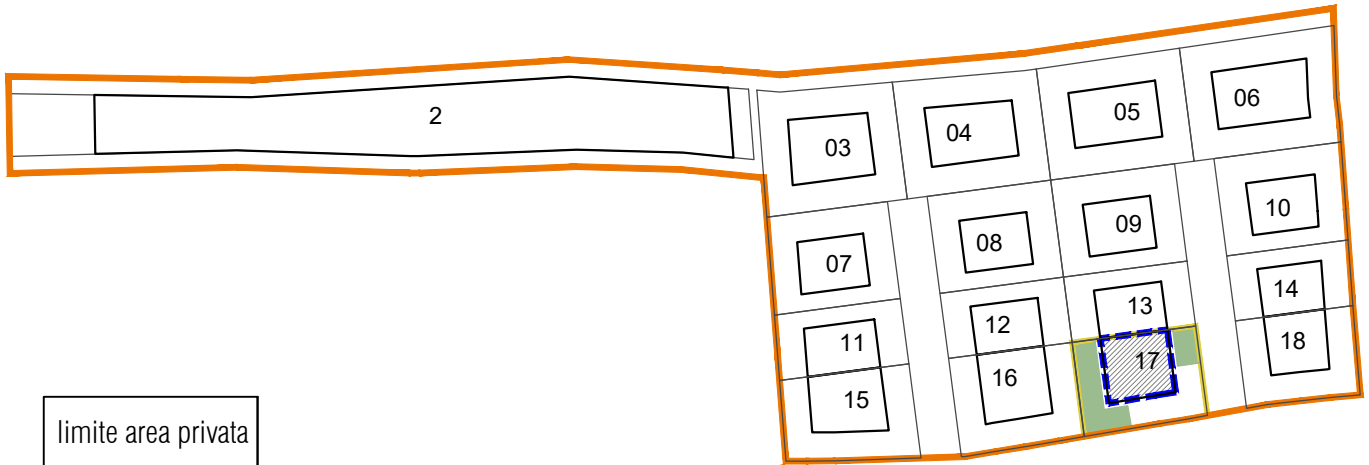

LOTTO mq	SCO mq =max ingombro	H max ml	livelli n.	SUL max mq	Volume mc
354	133	9.50	2	266	891

SP mq	IP
100%	
109	> 30%

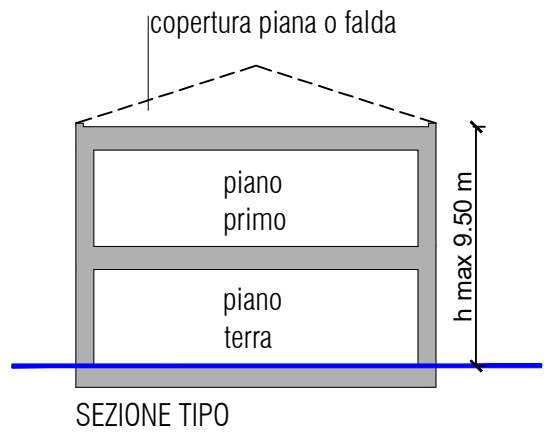
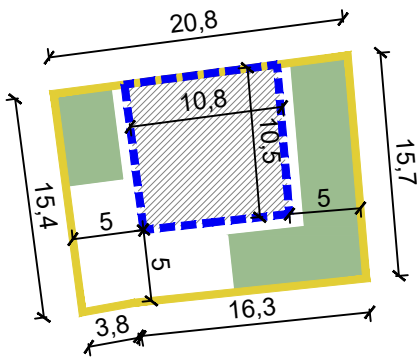
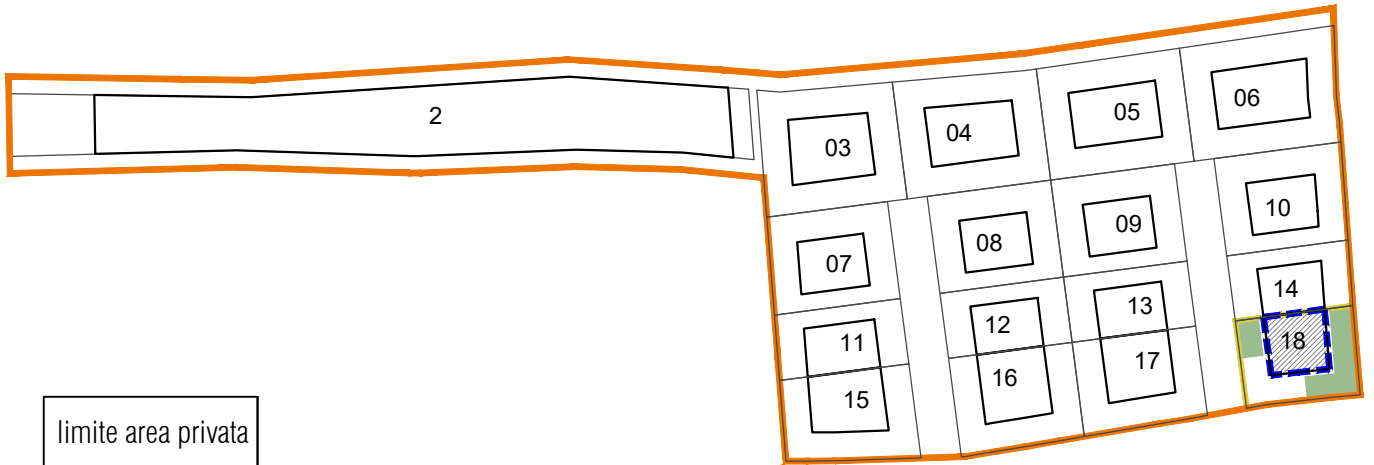

LOTTO mq	SCO mq =max ingombro	H max ml	livelli n.	SUL max mq	Volume mc
314	109	9.50	2	218	730

SP mq	IP
100%	
110	> 30%

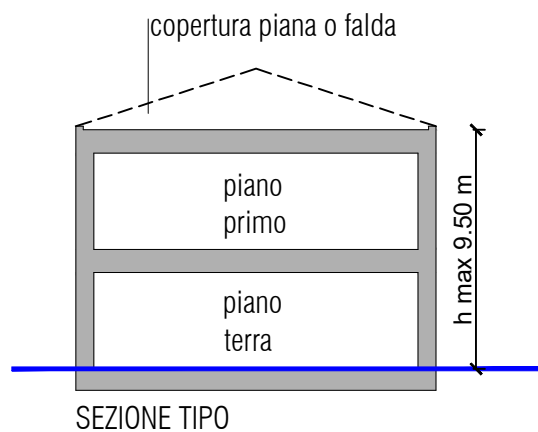
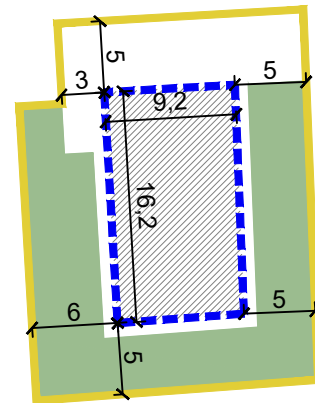
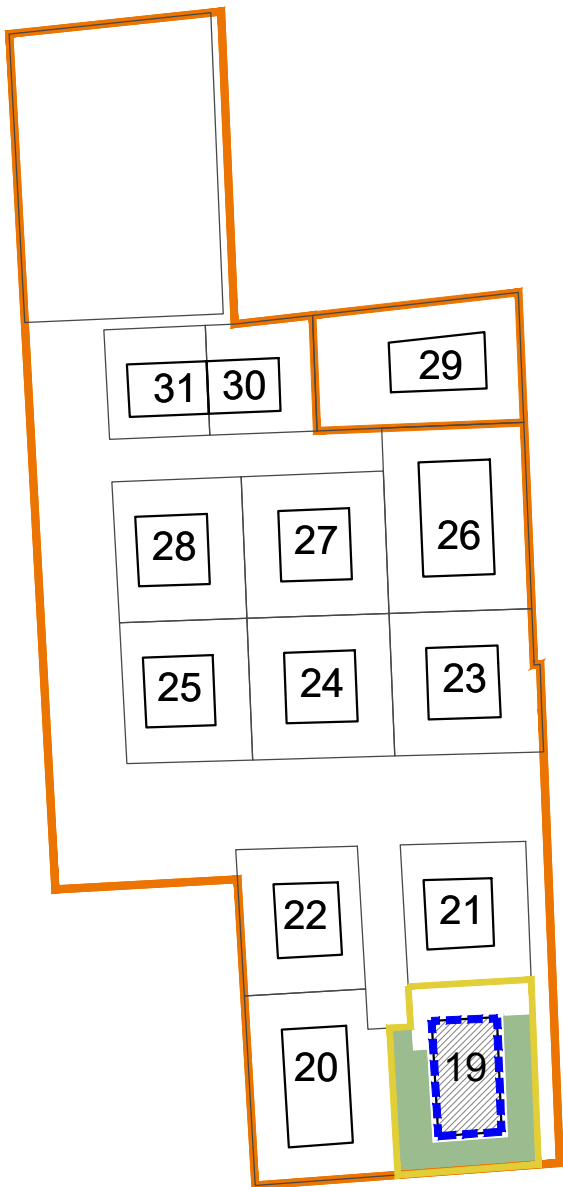

LOTTO mq	SCO mq =max ingombro	H max ml	livelli n.	SUL max mq	Volume mc
506	145	9.50	2	290	971

SP mq	IP
100%	
223	> 30%

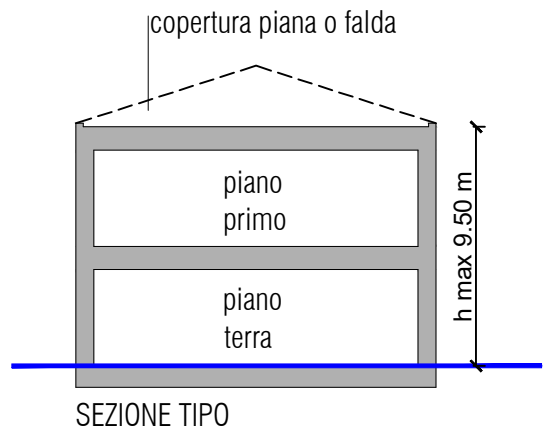
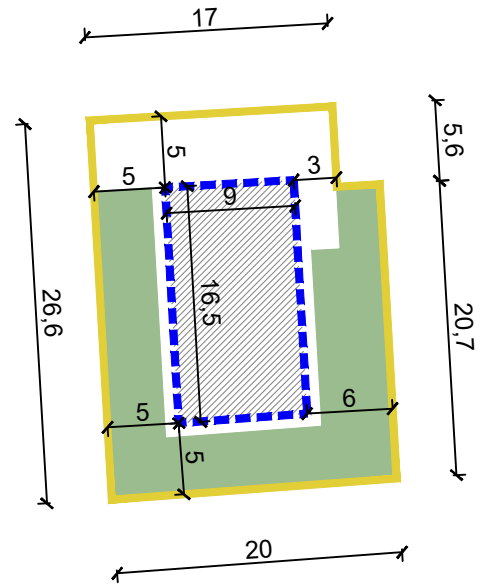
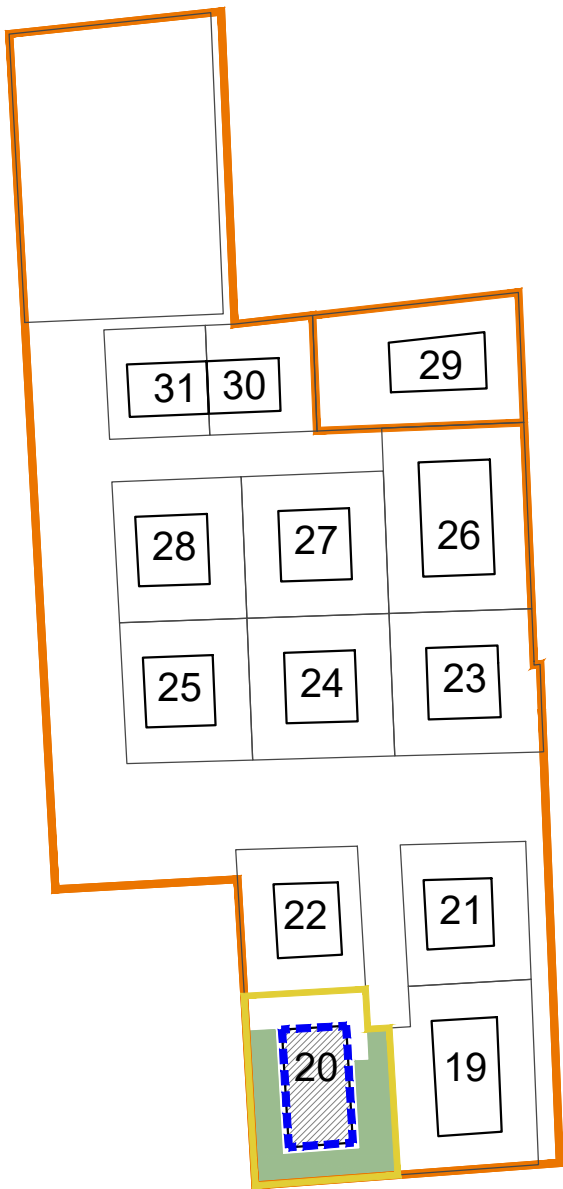

LOTTO mq	SCO mq =max ingombro	H max ml	livelli n.	SUL max mq	Volume mc
513	148	9.50	2	296	991

SP mq	IP
100%	
224	> 30%

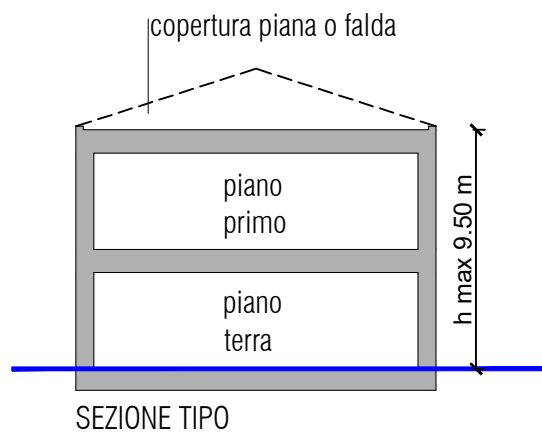
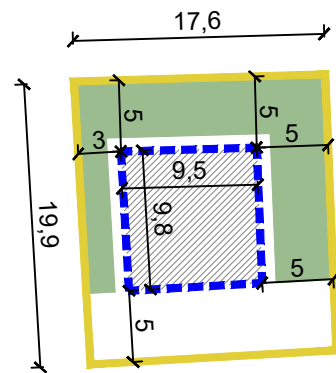
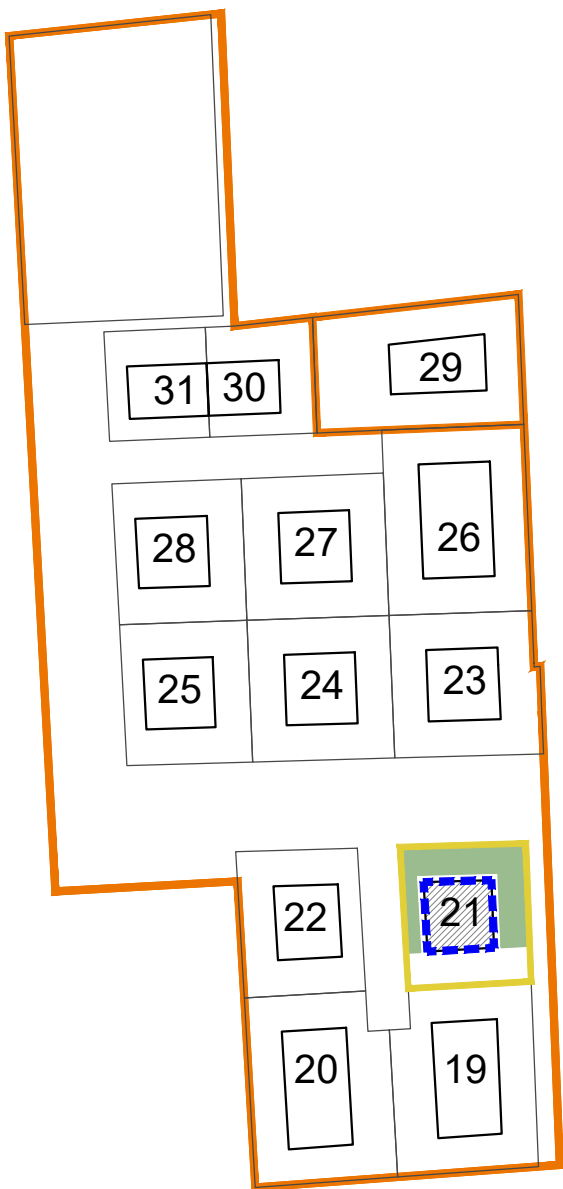

LOTTO mq	SCO mq =max ingombro	H max ml	livelli n.	SUL max mq	Volume mc
342	91	9.50	2	182	610

SP mq	IP
100%	
134	> 30%

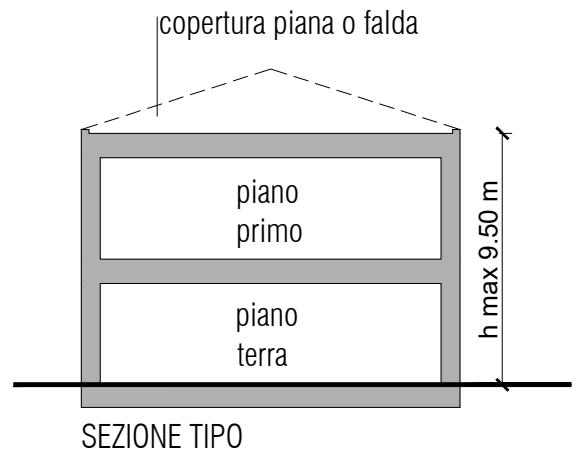
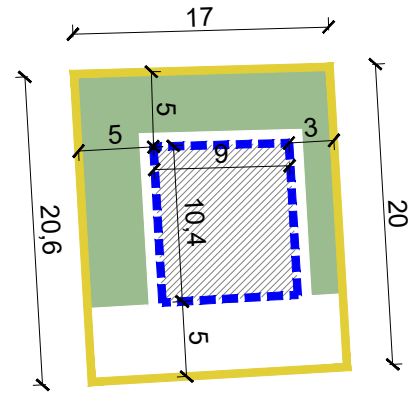
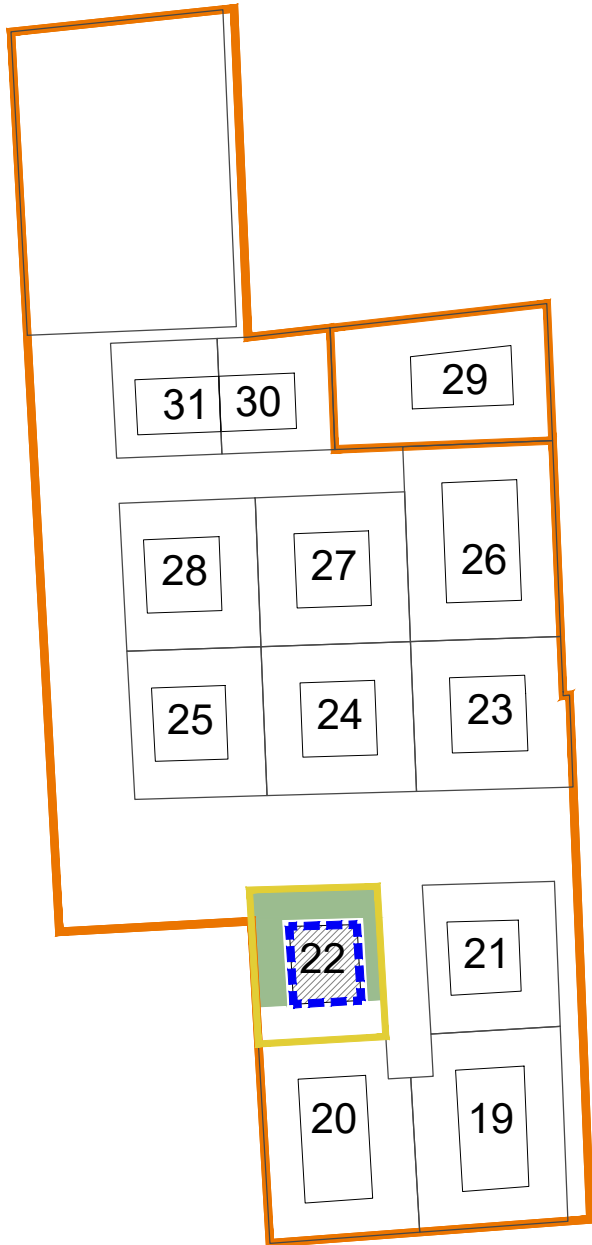

LOTTO mq	SC0 mq = max ingombro	H max ml	livelli n.	SUL max mq	Volume mc
345	92	9.50	2	184	616

SP mq	IP
100%	
136	> 30%

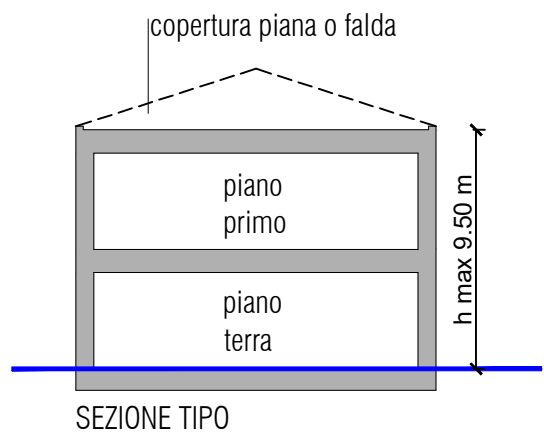
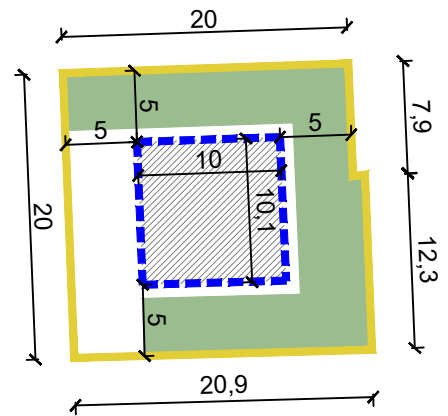
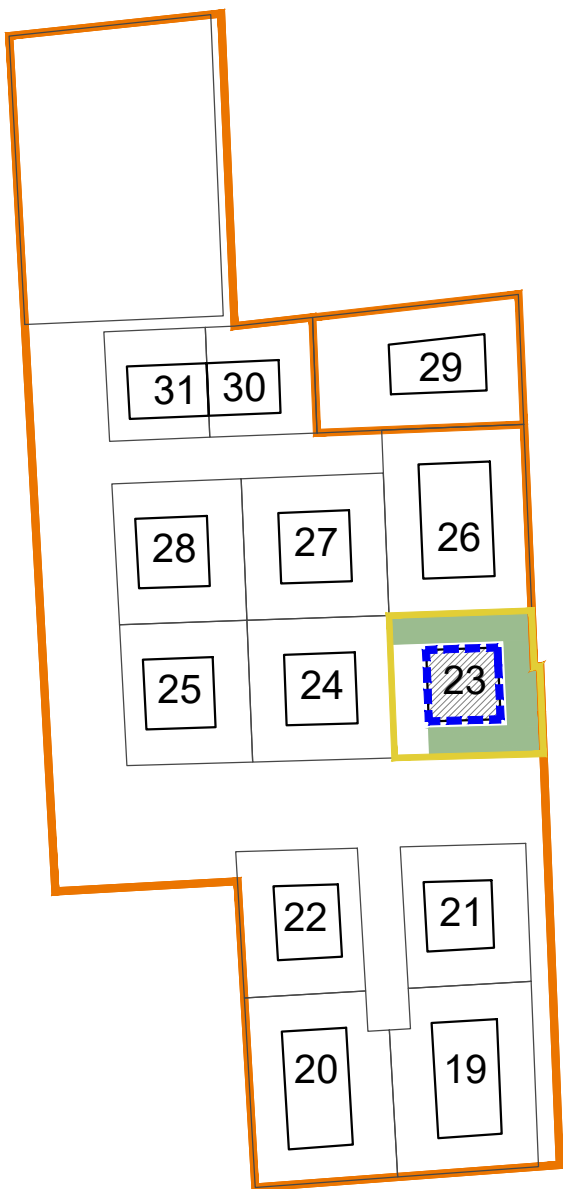

LOTTO mq	SCO mq =max ingombro	H max ml	livelli n.	SUL max mq	Volume mc
412	101	9.50	2	202	676

SP mq	IP
100%	
199	> 30%



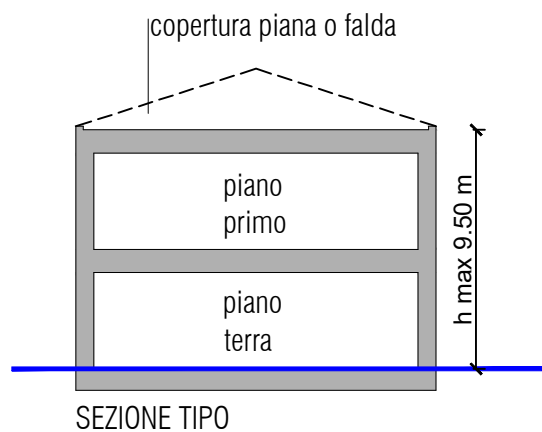
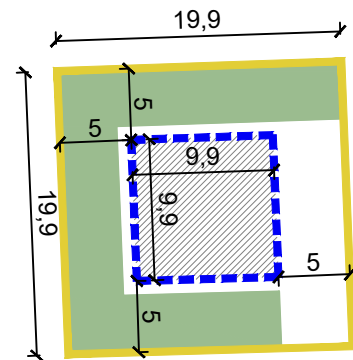
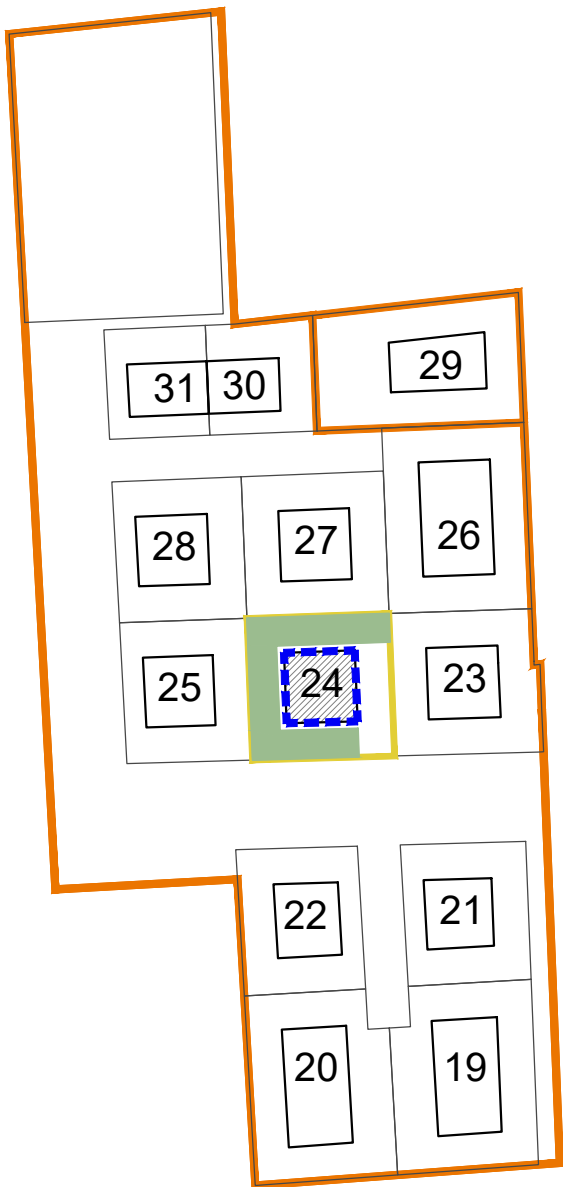

LOTTO mq	SCO mq =max ingombro	H max ml	livelli n.	SUL max mq	Volume mc
397	98	9.50	2	196	656

SP mq	IP
100%	
187	> 30%

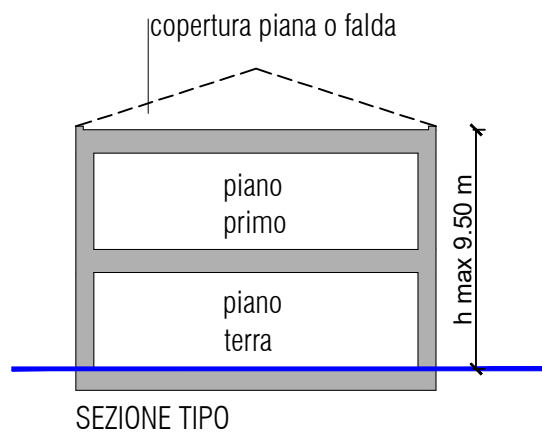
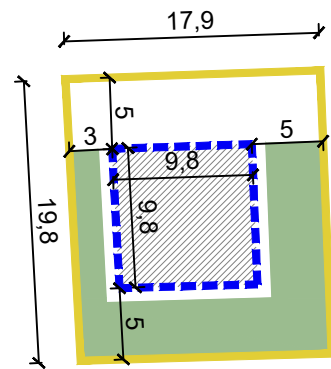
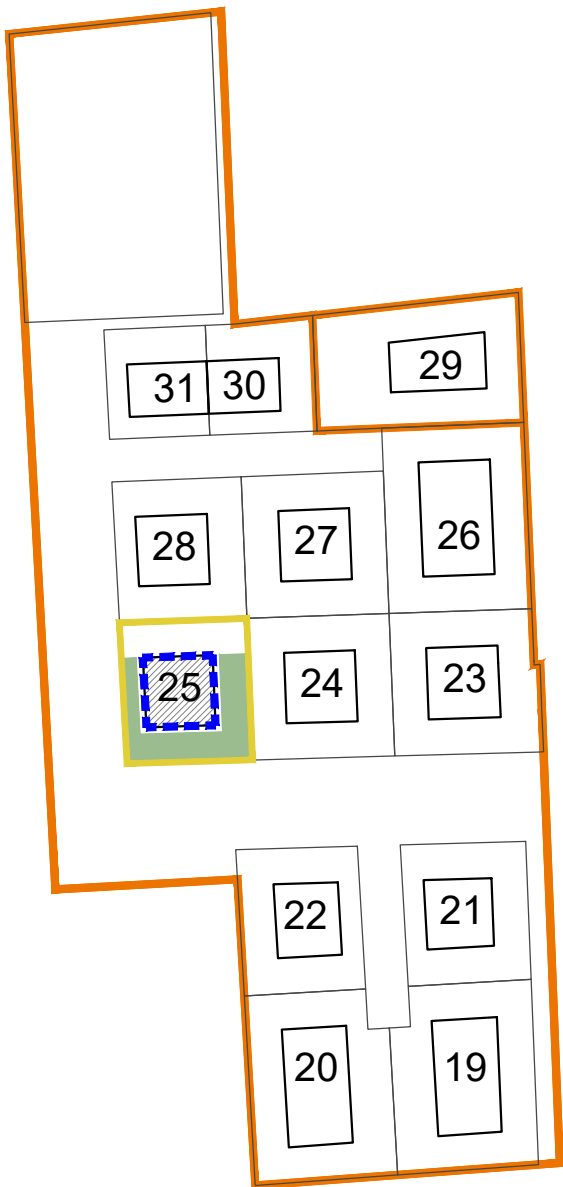

LOTTO mq	SCO mq =max ingombro	H max ml	livelli n.	SUL max mq	Volume mc
351	95	9.50	2	190	636

SP mq	IP
100%	
135	> 30%

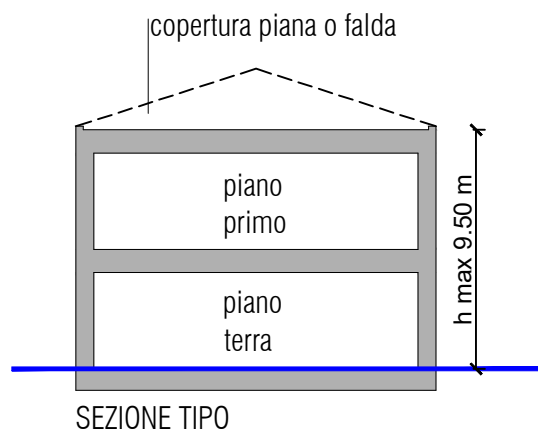
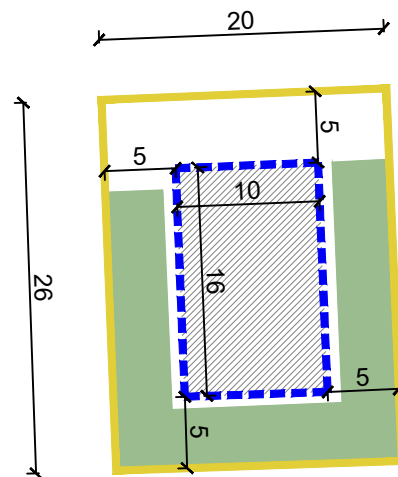
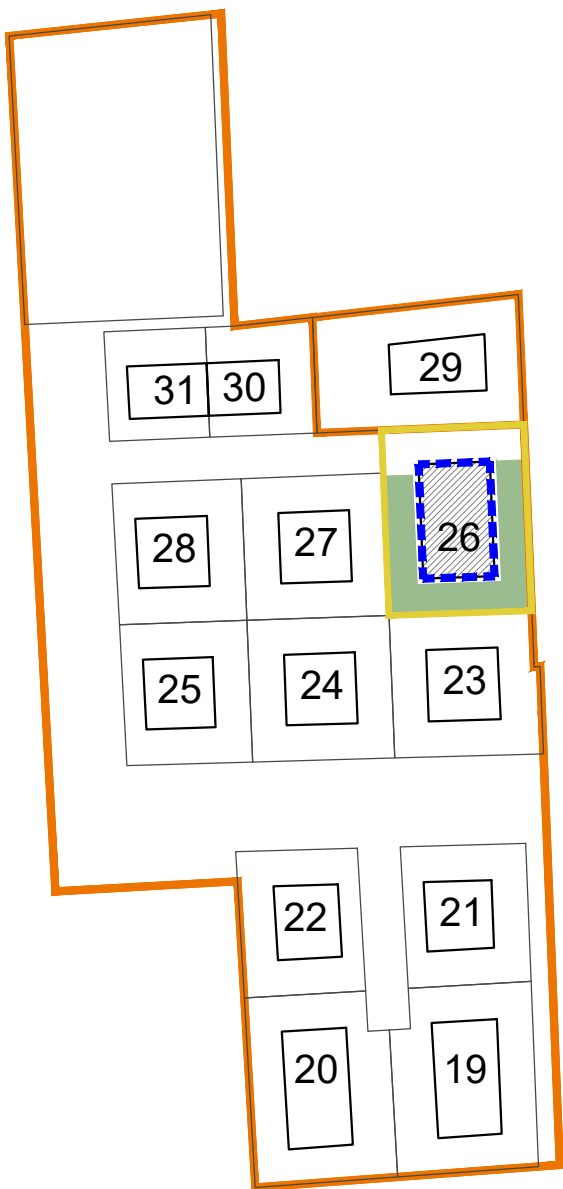

LOTTO mq	SCO mq =max ingombro	H max ml	livelli n.	SUL max mq	Volume mc
521	160	9.50	2	320	1 072

SP mq	IP
100%	
213	> 30%

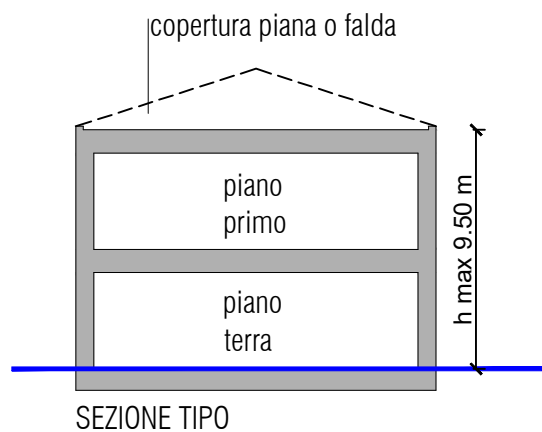
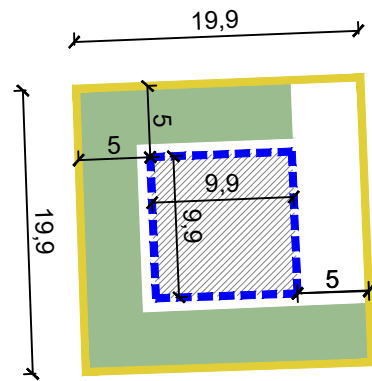
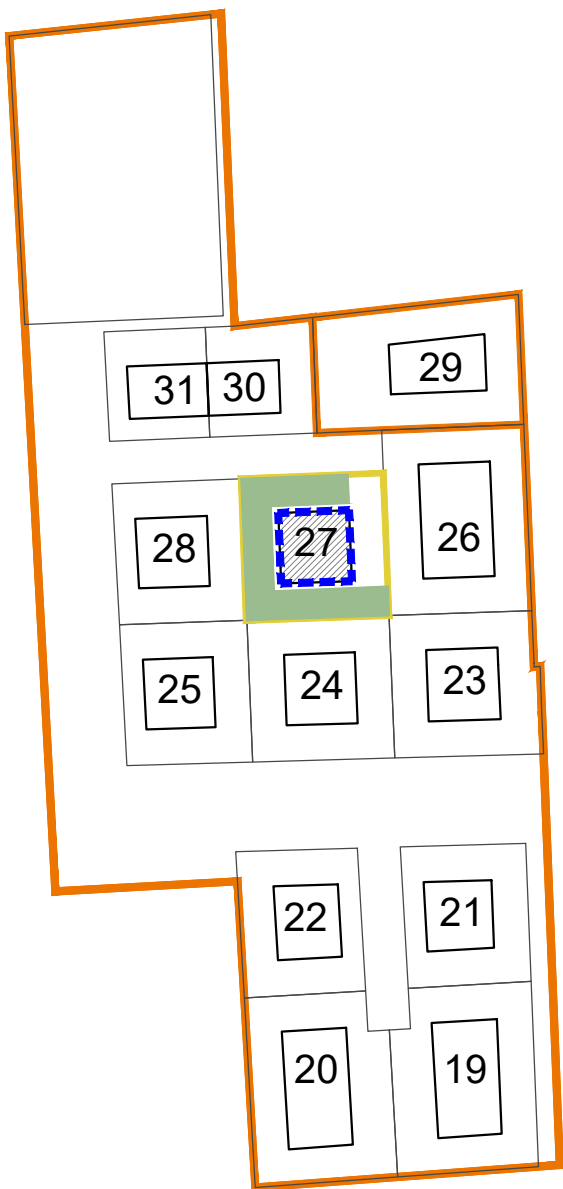

LOTTO mq	SCO mq =max ingombro	H max ml	livelli n.	SUL max mq	Volume mc
397	98	9.50	2	196	656

SP mq	IP
100%	
188	> 30%

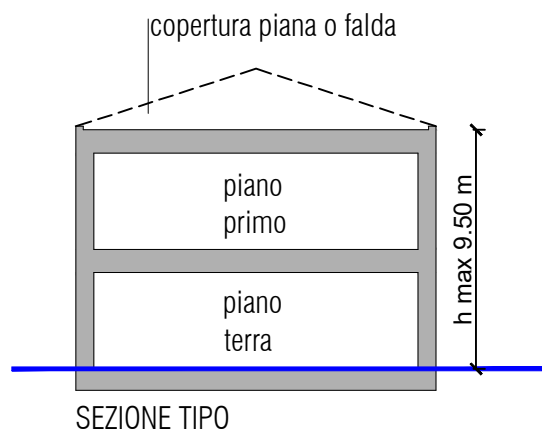
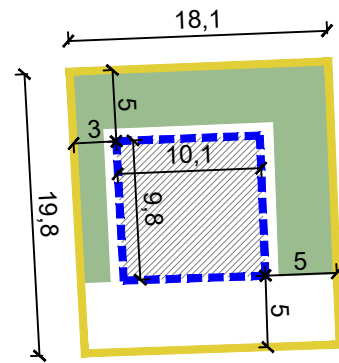
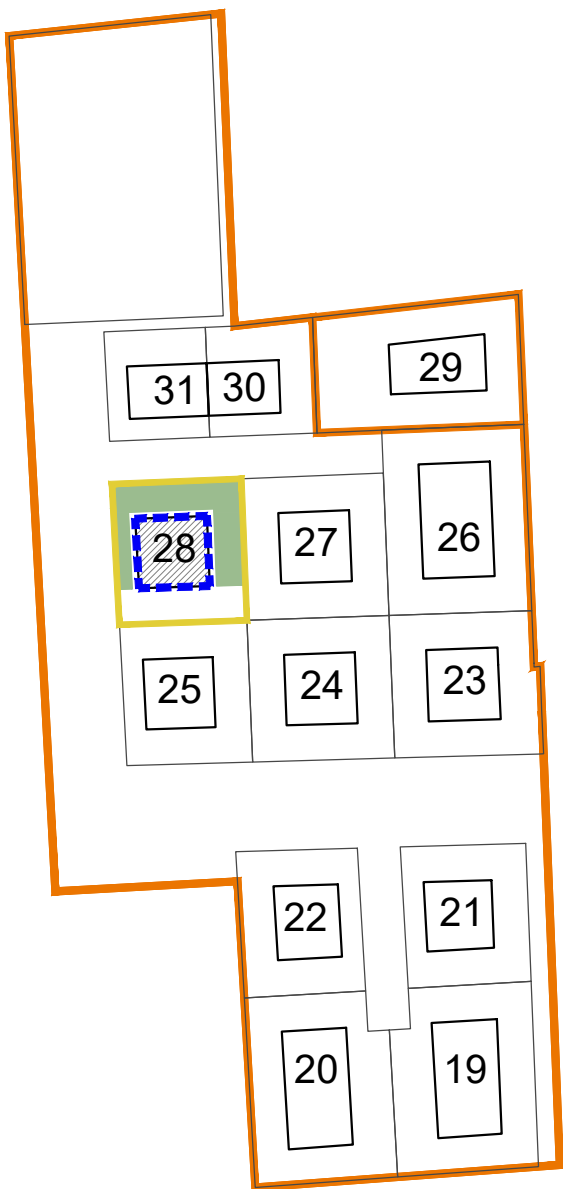

LOTTO mq	SCO mq =max ingombro	H max ml	livelli n.	SUL max mq	Volume mc
357	98	9.50	2	196	656

SP mq	IP
100%	
138	> 30%

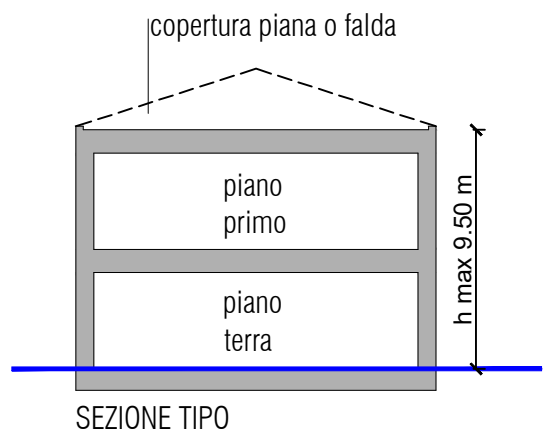
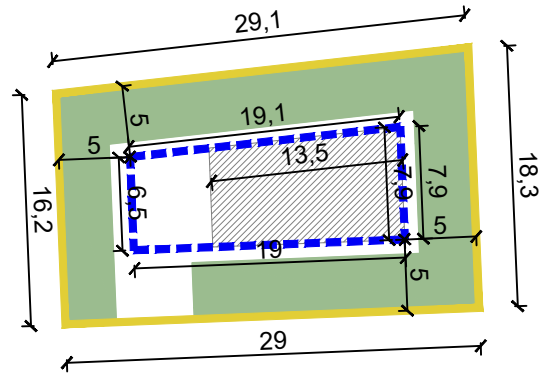
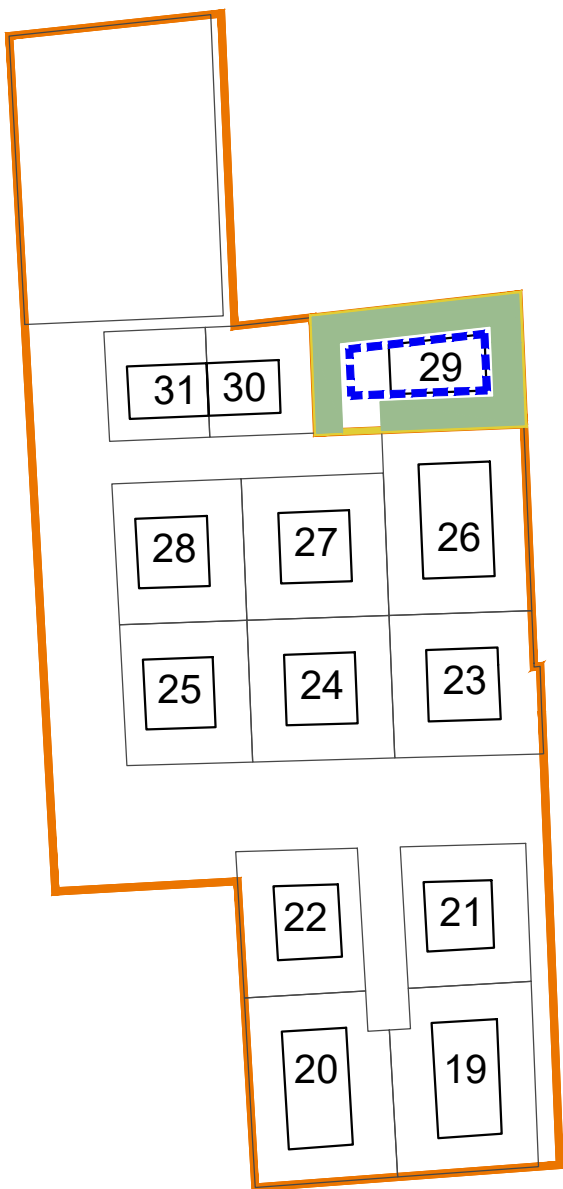

LOTTO mq	SCO mq =max ingombro	H max ml	livelli n.	SUL max mq	Volume mc
500	100	9.50	2	200	670

SP mq	IP
100%	
278	> 30%

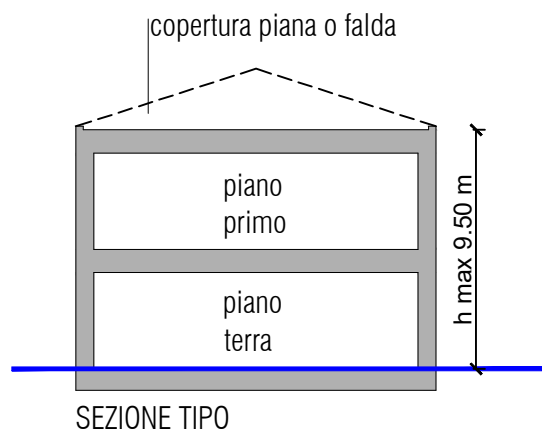
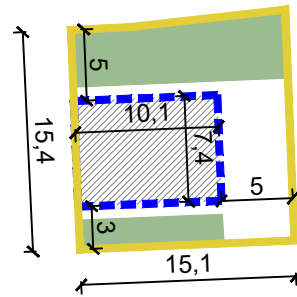
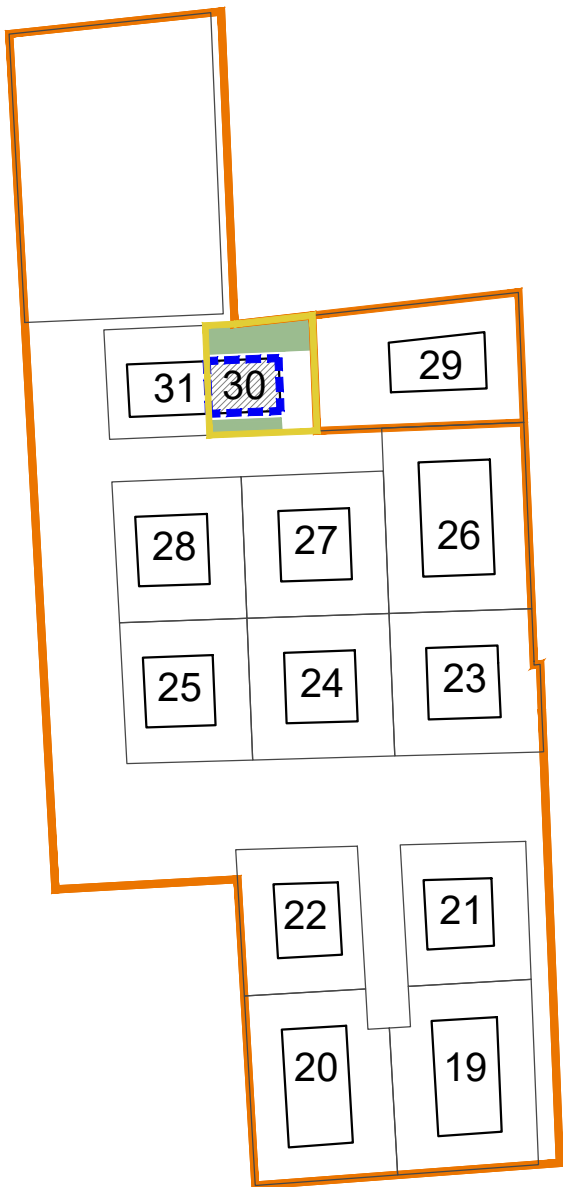

LOTTO mq	SCO mq =max ingombro	H max ml	livelli n.	SUL max mq	Volume mc
236	74	9.50	2	148	496

SP mq	IP
100%	
85	> 30%

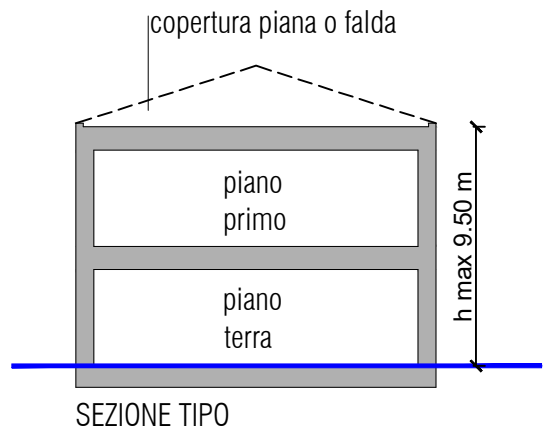
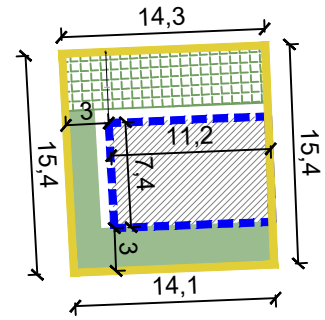
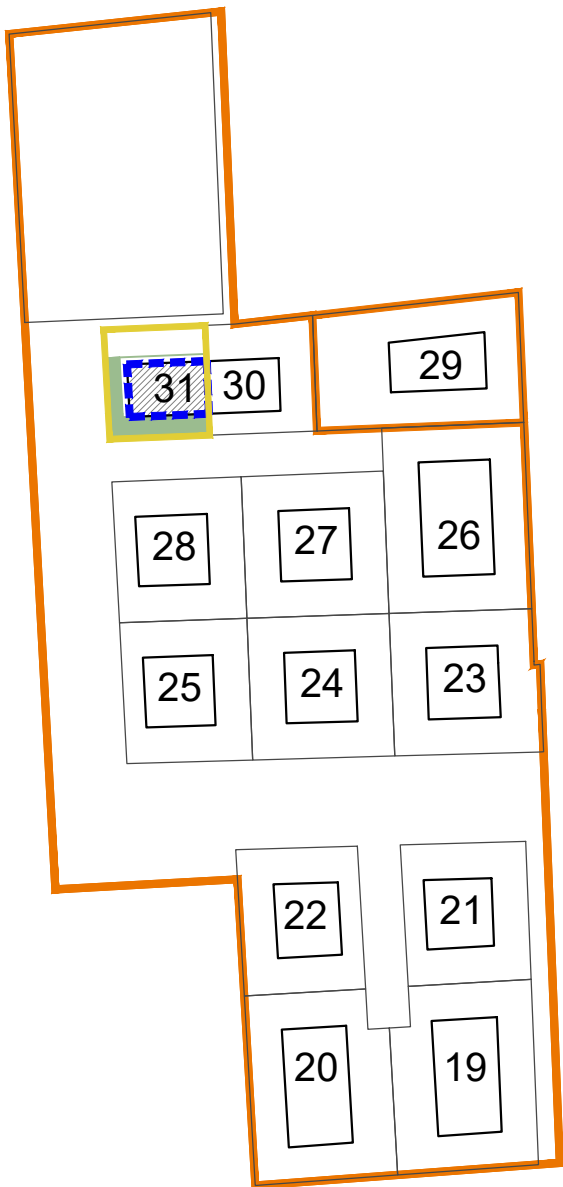

LOTTO mq	SCO mq =max ingombro	H max ml	livelli n.	SUL max mq	Volume mc
218	82	9.50	2	164	549

SP mq	SP mq	IP
100%	betonelle drenanti 20%	
59	57x0,20=11	> 30%



# EDIFICIO F1

# SCHEDA 193

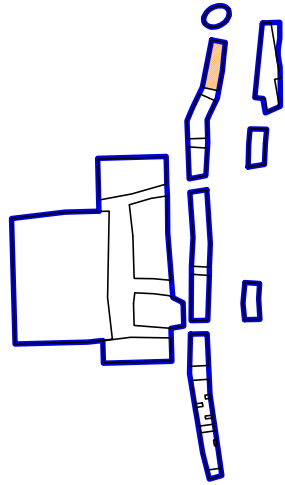

max ingombro	
filo edilizio	
DESTINAZIONE	residenziale direzionale
H. max ml	17.00
Volume mc	7.744
SUP.COP. mq	414

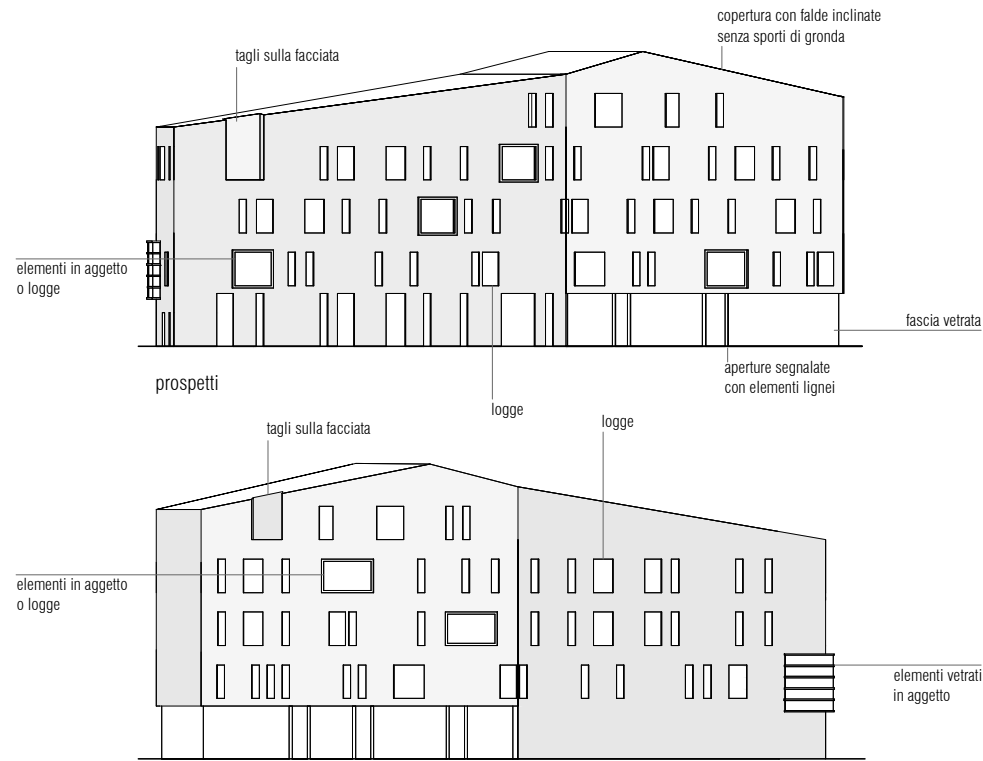
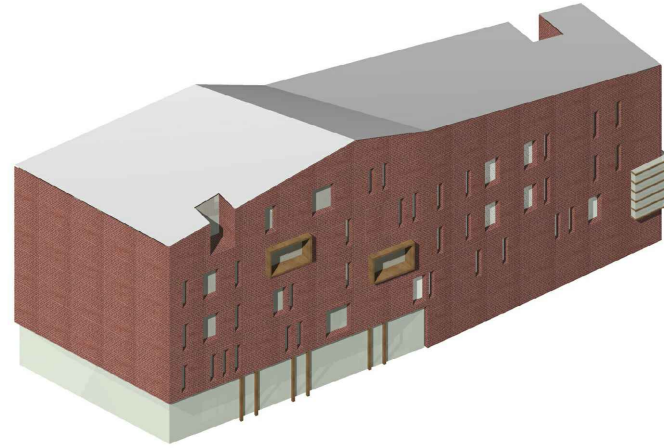
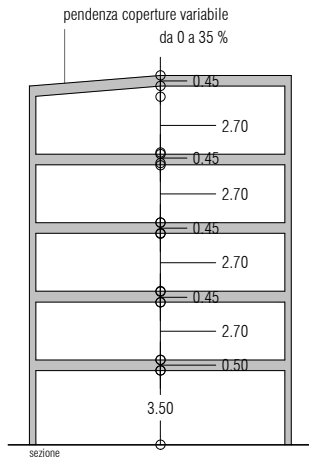

- 1/ mattoni faccia a vista
- 2/ -pareti rivestite in legno o pannelli tipo PARKLEX  
-aggetti vetrati con infissi in legno o alluminio
- 3/ lastre grecate di alluminio, rame, zinco con colorazione neutra o tegole in laterizio
- 4/ alluminio verniciato o legno naturale
- 5/ fascia vetrata senza montanti con ingressi alle attività realizzati con telai in legno

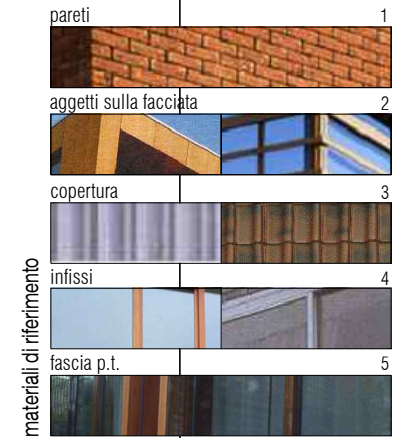

# EDIFICIO F2

# SCHEDA 193

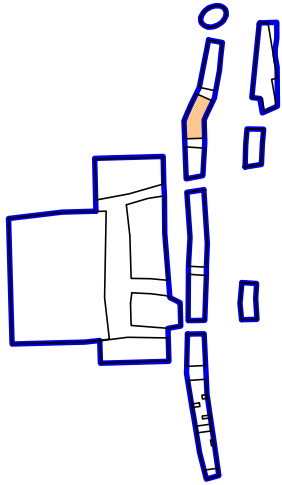

max ingombro	
filo edilizio	
DESTINAZIONE	residenziale direzionale
H. max ml	17.00
Volume mc	8.296
SUP.COP. mq	446

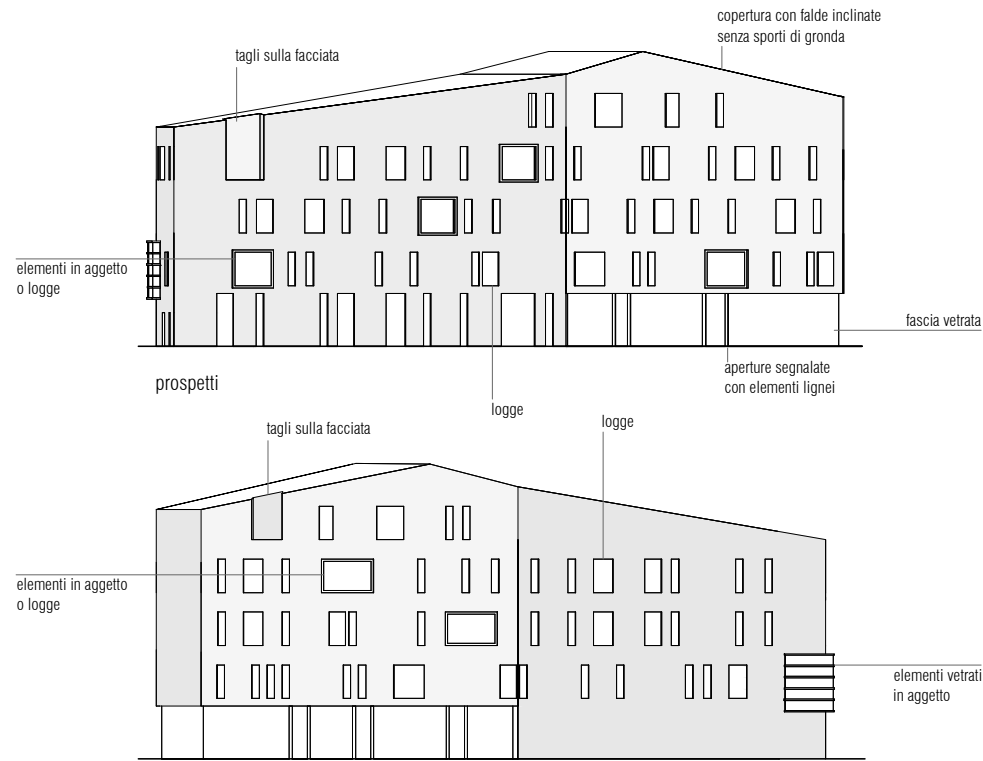
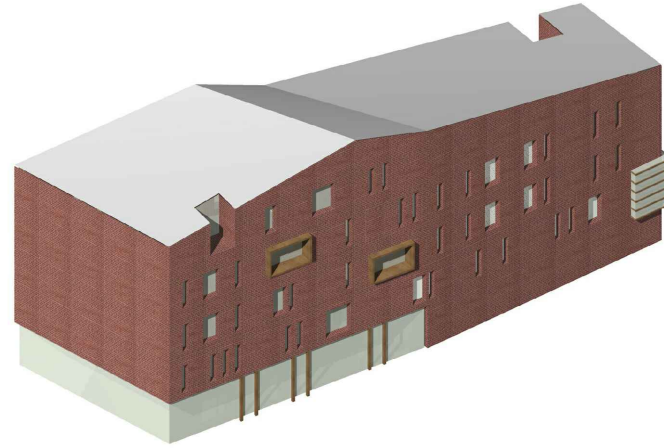
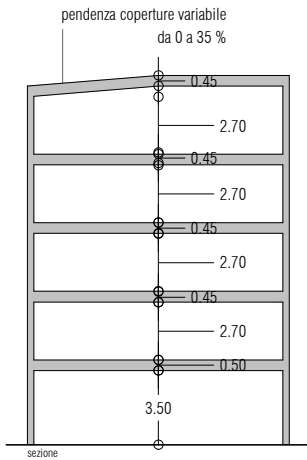

- 1/ mattoni faccia a vista
- 2/ -pareti rivestite in legno o pannelli tipo PARKLEX  
-aggetti vetrati con infissi in legno o alluminio
- 3/ lastre greccate di alluminio, rame, zinco con colorazione neutra o tegole in laterizio
- 4/ alluminio verniciato o legno naturale
- 5/ fascia vetrata senza montanti con ingressi alle attività realizzati con telai in legno

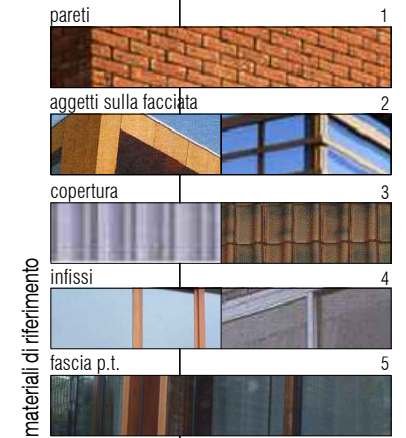

materiali di riferimento

# EDIFICIO N

# SCHEDA 193

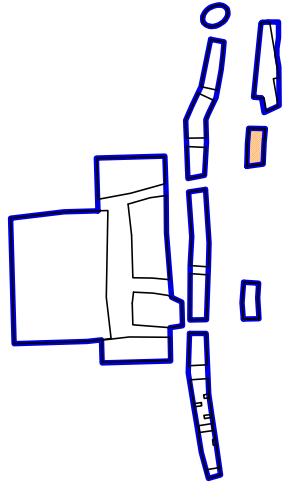

max ingombro		
filo edilizio		
DESTINAZIONE	residenziale direzionale	
H. max ml	17.00	
Volume mc	5 627	
SUP. COP. mq	331	

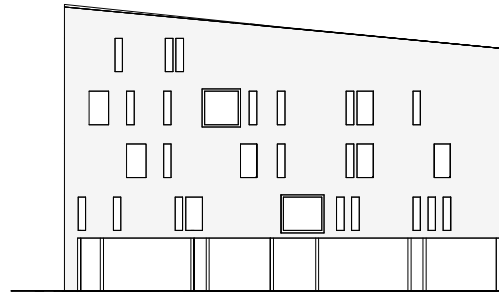
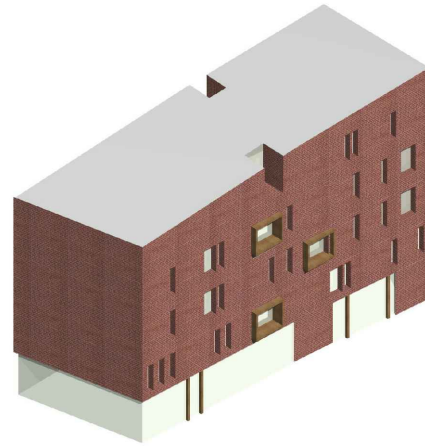
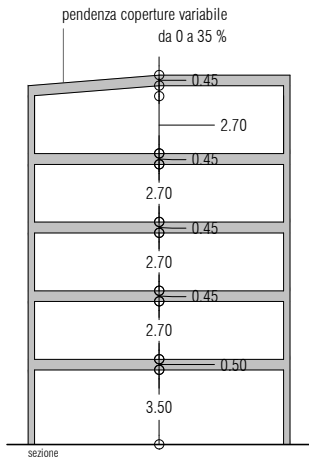

prospetti

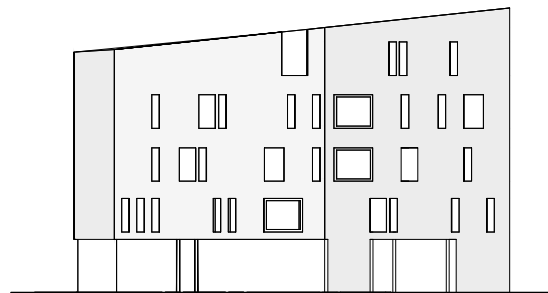

# EDIFICIO 0

# SCHEDA 193

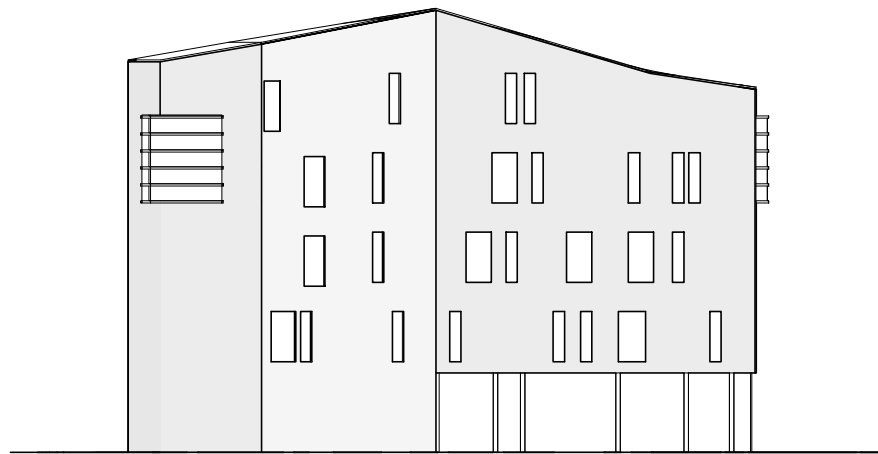
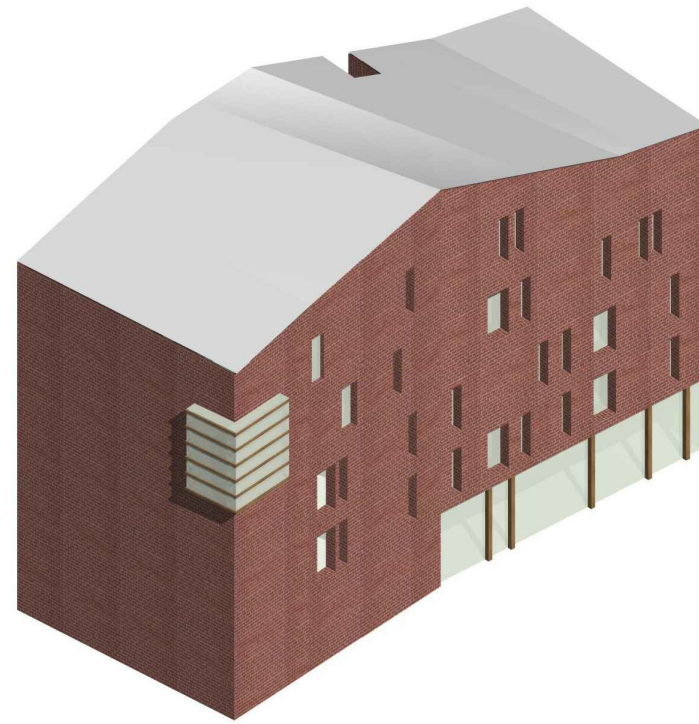
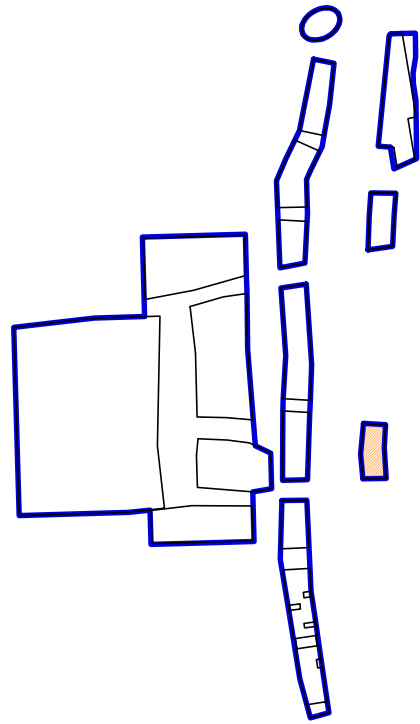

prospetti

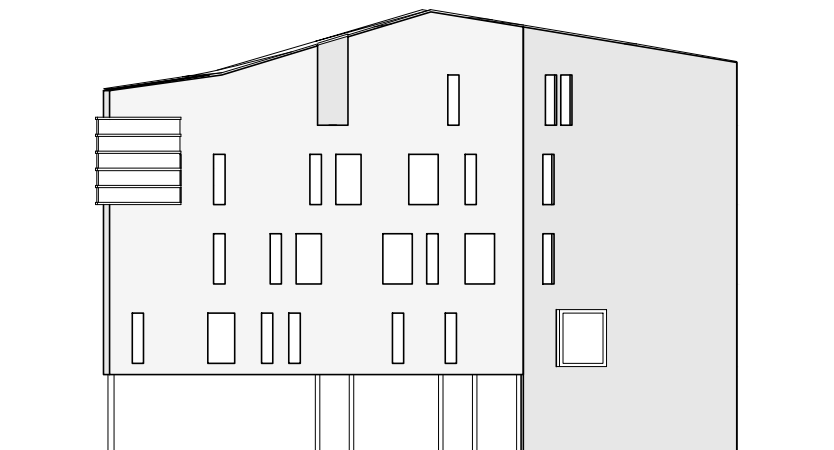

max ingombro	
filo edilizio	
DESTINAZIONE	residenziale direzionale
H. max ml	17.00
Volume mc	5 168
SUP.COP. mq	304

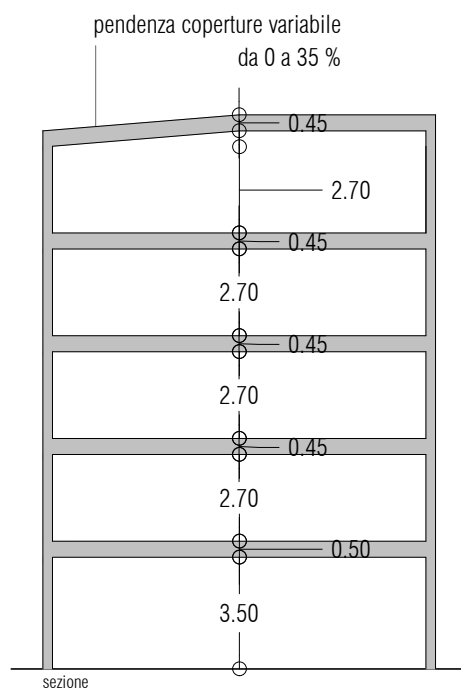

# EDIFICIO S

# SCHEDA 193

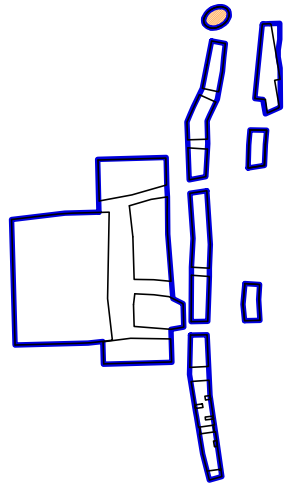

max ingombro		
fito edilizio		
DESTINAZIONE	direzionale	35
	residenziale	
	commerciale	
H. max ml	35	
Volume mc	7 755	35.00
SUP.COP. mq	222	

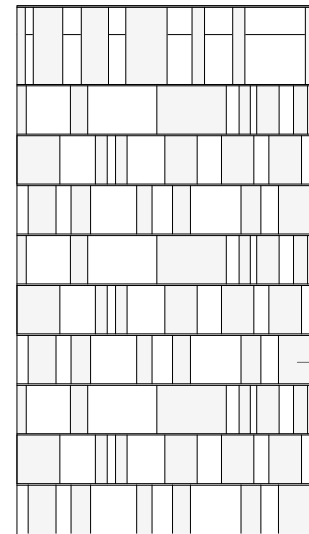
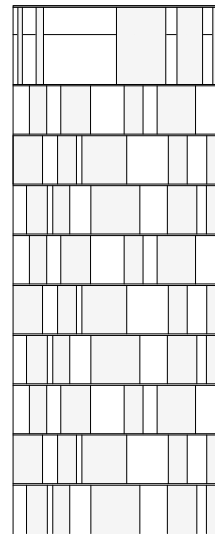
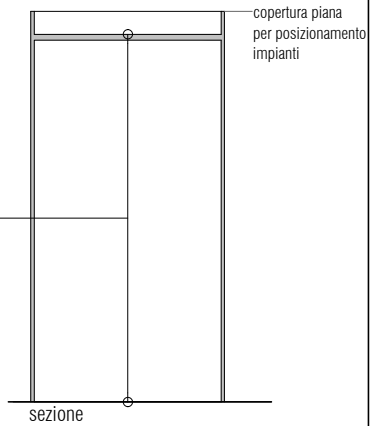

copertura piana per posizionamento impianti

logge scavate nel volume

superficie esterna realizzata con materiali omogenei di pregio da valutarsi in sede progettuale

pareti



materiali di riferimento

1/ superficie esterna realizzata con materiali omogenei di pregio da valutarsi in sede progettuale come:  
mattoni  
vetro  
metallo  
legno